

200

Bau- und Spielbuch **Libro Idee**

Livre d'idées **Ideeënboek** **Libro de ideas**

Byggebog **Building Book** **Byggidébok**

Livro de sugestões **Rakennusvihjekirja**

Byggebok **Βιβλίο Κατασκευών**





 Hier in diesem tollen Baubuch findest Du viele Anregungen und Ideen für's Bauen und Spielen mit LEGO® Steinen. Es kann allerdings vorkommen, daß Du bei dem einen oder anderen Bauvorschlag Teile siehst, die Du noch nicht hast. Das ist nicht weiter schlimm. Nimm ganz einfach ein ähnliches LEGO Element und bau damit weiter. Du wirst sehen, das Modell wird genauso schön. Du weißt ja, wichtig ist doch eigentlich nur, daß Du mit den LEGO Steinen immer etwas Neues bauen kannst.

 Questo libro contiene idee e suggerimenti per costruire con i mattoncini LEGO®. Potreste non riuscire a costruire esattamente tutto ciò che è illustrato perchè non possedete gli stessi tipi di mattoncini. Provate comunque! L'importante è imparare ad usare gli elementi da costruzione in tanti modi diversi. Buon gioco!

 Ce livre vous donne plein d'idées pour construire et jouer avec les briques LEGO®. Vous ne pourrez peut-être pas reproduire tous les modèles exactement comme ils sont illustrés parce qu'il vous manque certains éléments. Mais construisez quand même. La chose la plus importante est d'utiliser, de manières différentes, les briques que vous avez déjà. Amusez-vous bien!

 Dit boek draagt ideeën aan voor het bouwen en spelen met je eigen verzameling LEGO® steentjes. Voor sommige werkstukken kan je dus wel iets tekort komen. Dan zal je zelf een oplossing moeten vinden met andere LEGO elementen. Vanuit de afbeelding zelf verder fantaseren is juist de grote LEGO uitdaging. Zo ontdek je de vele (vaak nieuwe) mogelijkheden van je verzameling. Aan de gang dus en... veel plezier!

 En este libro encontrarás ideas para construir y jugar con ladrillos LEGO®. A lo mejor no puedes construir algo exactamente igual a como lo ves, porque te falte alguna pieza. Constrúyelo con las piezas que tengas. Lo importante es que uses los ladrillos que ya tienes con ideas nuevas. ¡Que te diviertas!

 Denne byggebog giver ideer og inspiration til byggeri og leg med LEGO® klodser. Det er ikke sikkert, du kan bygge alle modellerne nøjagtigt, som de er vist i bogen, fordi du mangler nogle af elementerne. Men byg alligevel. Det vigtigste er at bruge de klodser, du har, på nye måder. God fornøjelse!

 This book gives ideas for building and playing with LEGO® bricks. You may not be able to build all the things exactly as shown because you lack some of the pieces. But build anyway. The most important thing is to use the bricks you have in new ways. Have a good time!

 Denna bok ger dig idéer till hur du kan bygga och leka med LEGO® klossar. Du kanske inte kan bygga allt, precis som det är visat, för att du saknar en del klossar. Men försök att bygga i allafall. Det viktigaste är att använda de klossar du har på nya sätt. Ha det så roligt!

 Este livro oferece ideias para construir e brincar com as pedras LEGO®. Podes não ser capaz de construir todas as coisas exactamente como se mostram porque te faltam algumas peças. De qualquer modo, constrói. O mais importante é usares as pedras que tens de maneiras novas. Diverte-te.

 Tämä kirja tarjoaa vihjeitä rakentamiseen ja leikkeihin LEGO® palikoilla. Et ehkä kykene rakentamaan kaikkia kirjassa esitellyjä malleja aivan oikein, koska Sinulta ehkä puuttuu palikoita. Mutta yritä kuitenkin. Tärkeintä on käyttää palikoita uusilla tavoilla. Pidä hauskaa!

 Denne boken gir deg ideer til lek og bygging med LEGO® klosser. Du klarer kanskje ikke å bygge alt slik det vist fordi du mangler noen klosser. Men bygg i vei. Husk, det viktigste er at du bruker de klossene du har. Lykke til!

 Αυτό το βιβλίο σας δίνει ιδέες για πολλές κατασκευές και παιχνίδια με τα τουβλάκια LEGO®. Μπορεί να μην μπορέσετε να κατασκευάσετε όλα τα αντικείμενα όπως ακριβώς παρουσιάζονται εδώ, γιατί ίσως σας λείπουν μερικά κομμάτια. Συνεχίστε όμως να κατασκευάζετε. Το σπουδαιότερο πράγμα είναι να χρησιμοποιήσετε τα τουβλάκια που ήδη έχετε, με νέους τρόπους. Καλή διασκέδαση!

 この本の中には、レゴ・ブロックで作品をつくらうときのヒントがたくさんついています。かんたんなものからむずかしいものまでいろいろ…。この一冊をヒントにすれば、たのしい創造の世界がぐーんとひろがります。でも、君の作品がこの本にのっているものとそっくりでなくてもよいのです。部品がたりなくても、気にしない。自分ならこう作る、と自分自身のアイデアをどんどんとり入れてください。自分自身の作品をつくり上げるところに、レゴ・ブロックのたのしさがあるのです。

BASIC

4-9



BASIC

10-15



LEGOLAND

16-27



LEGOLAND

28-39



LEGOLAND

40-47



LEGOLAND + BASIC

48-51



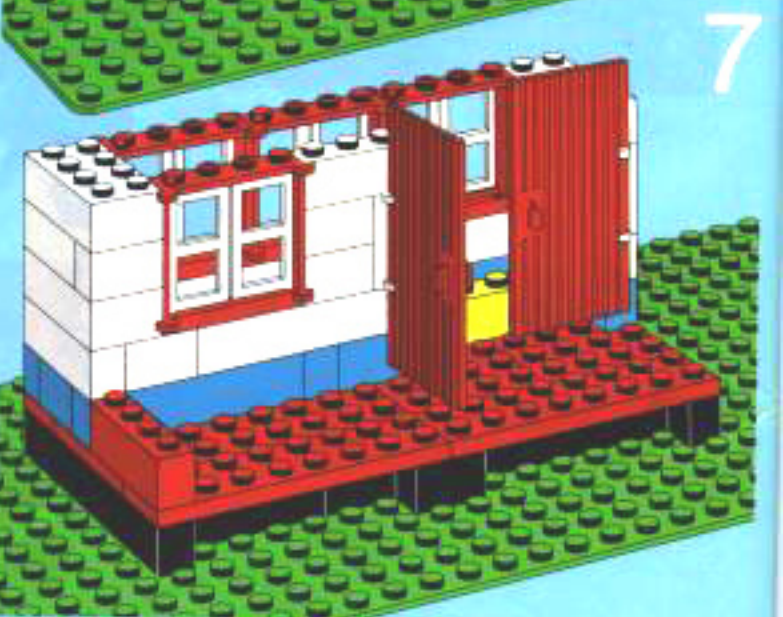
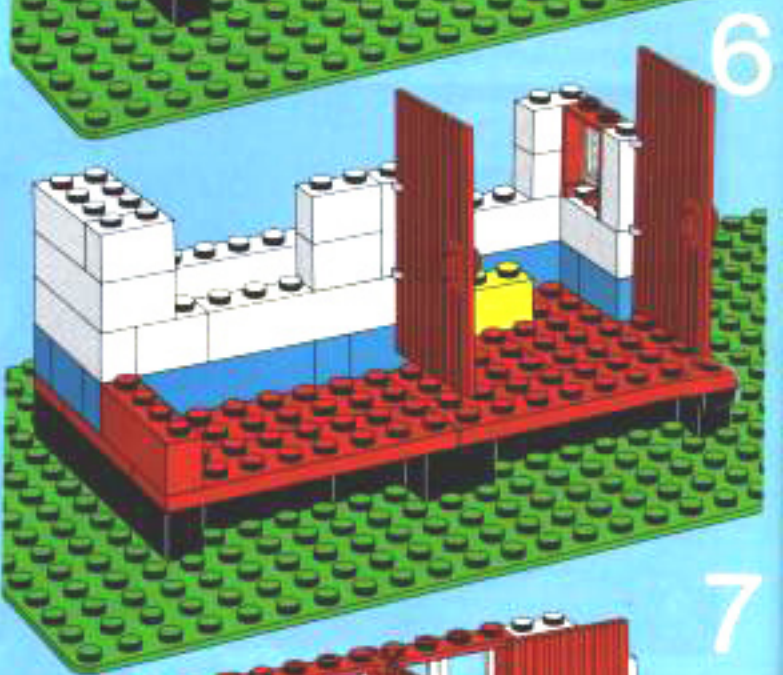
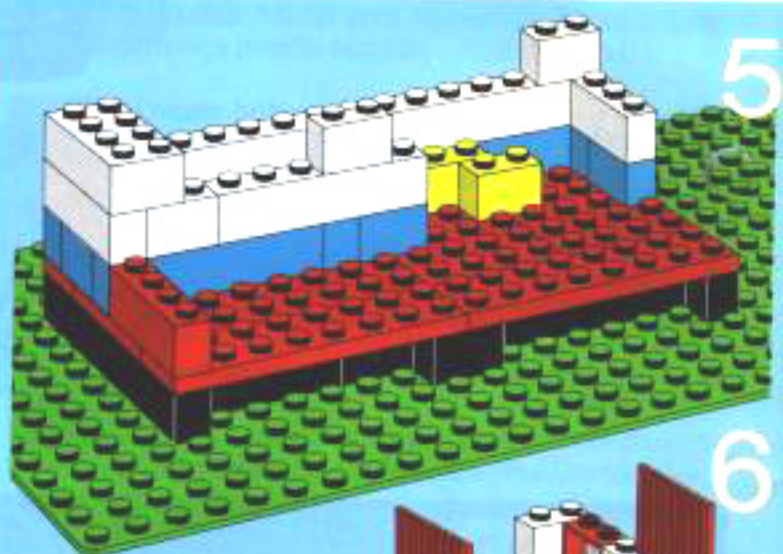
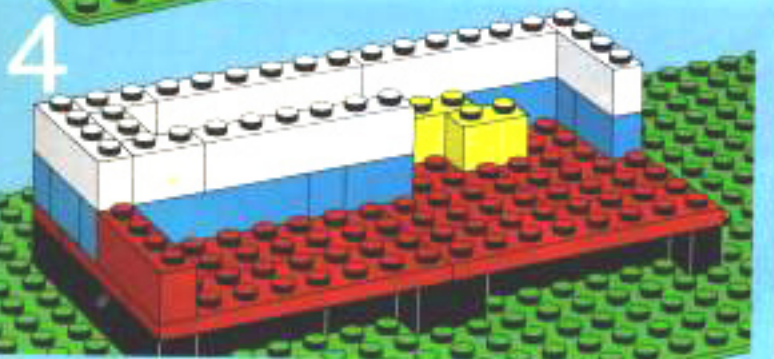
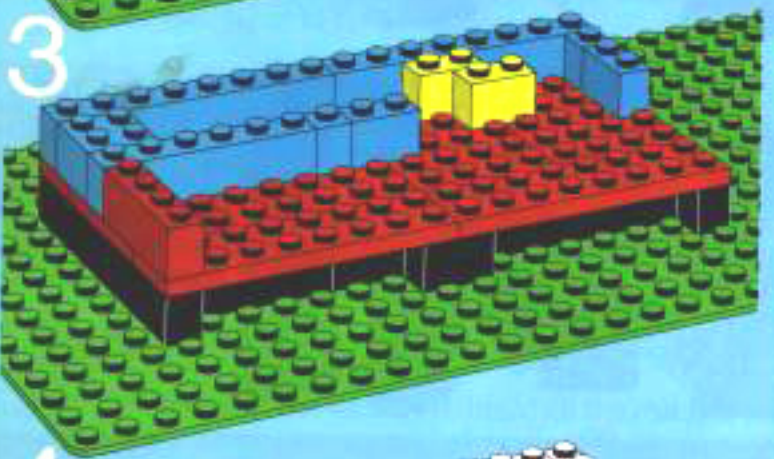
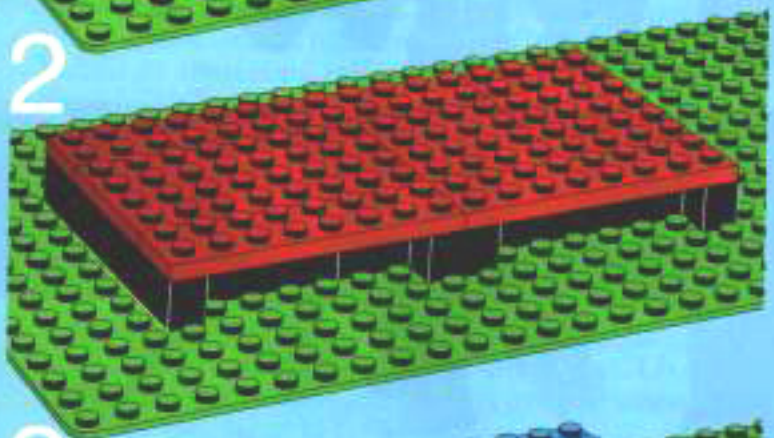
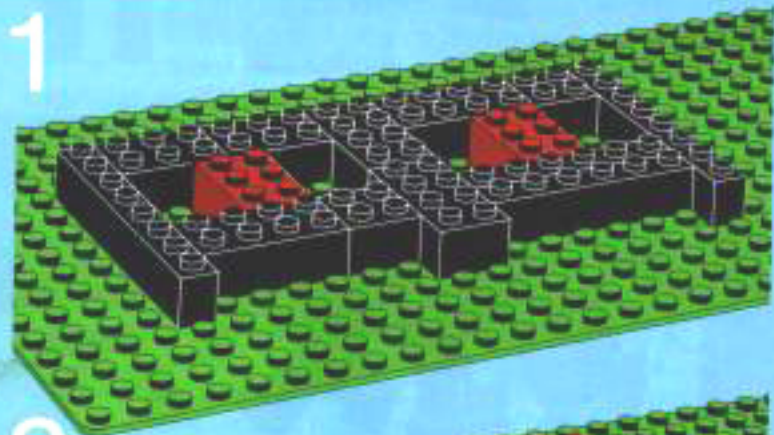



8

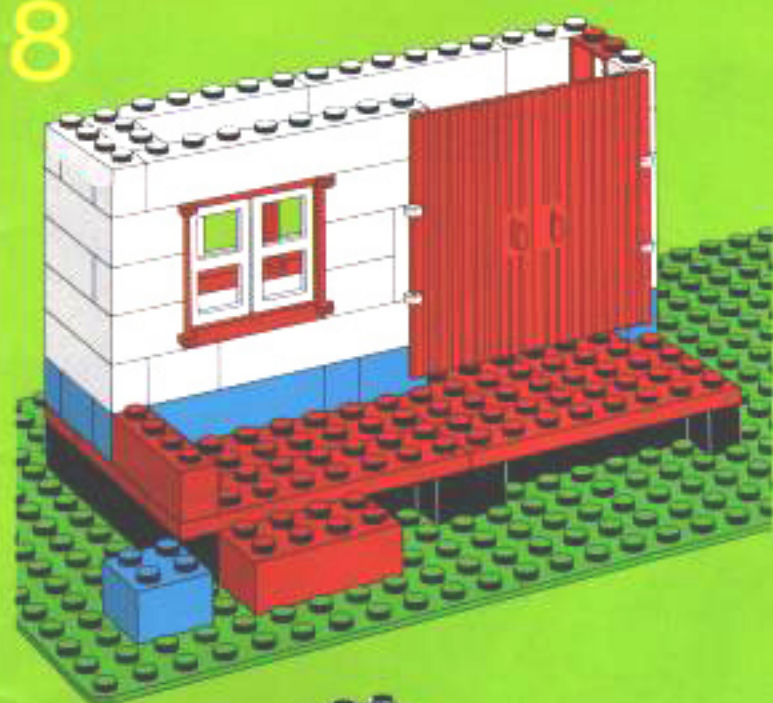

9

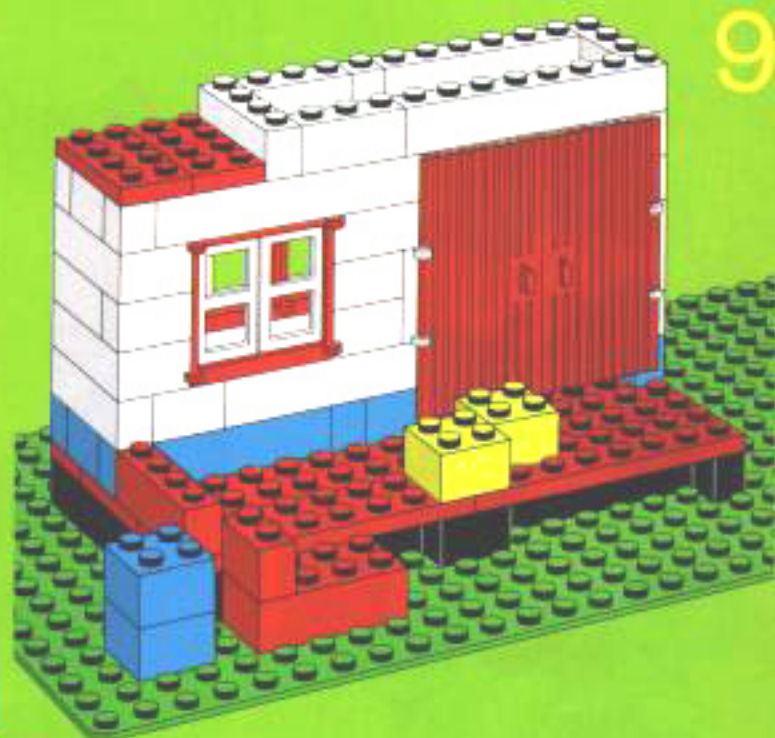

10

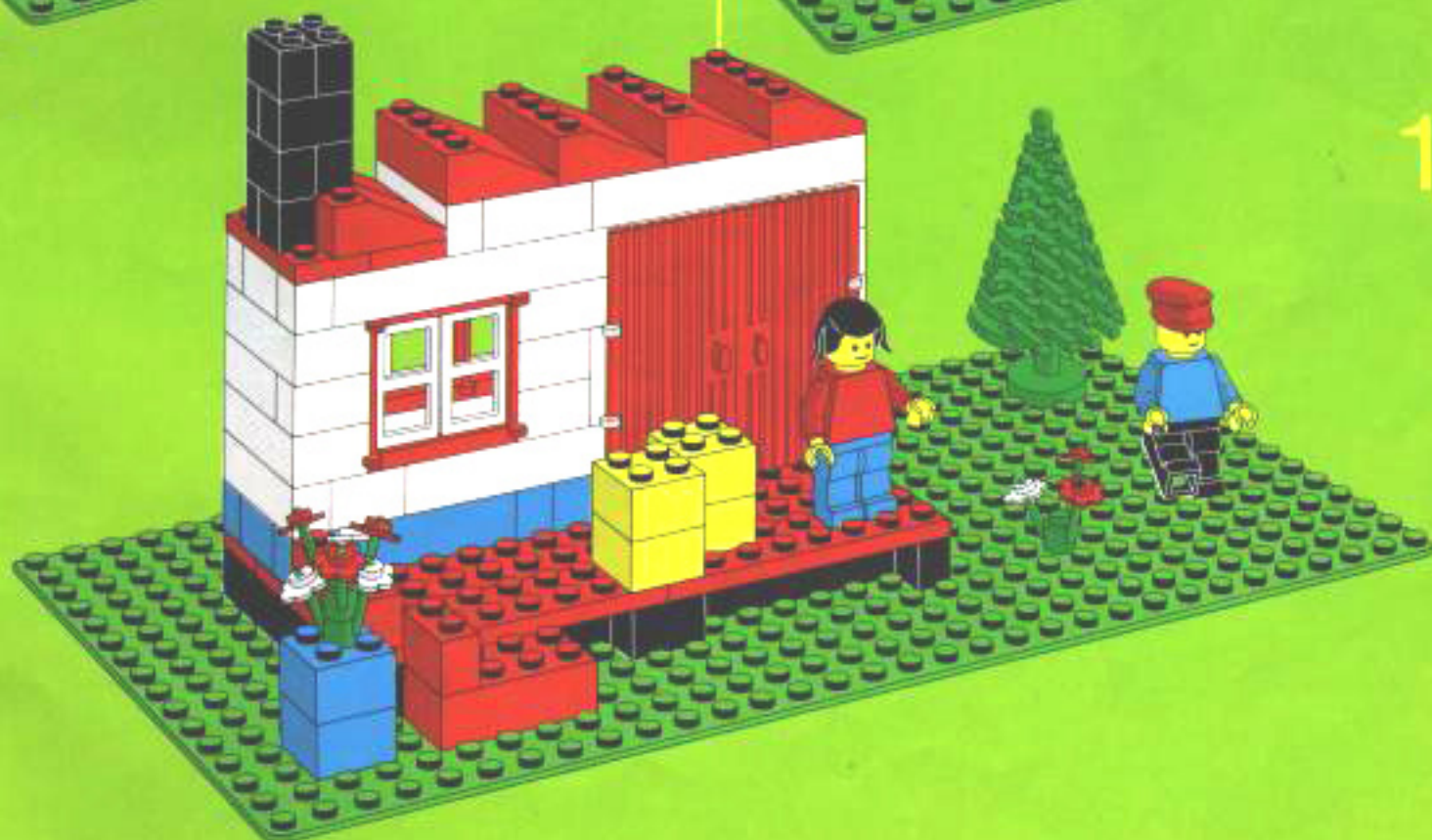

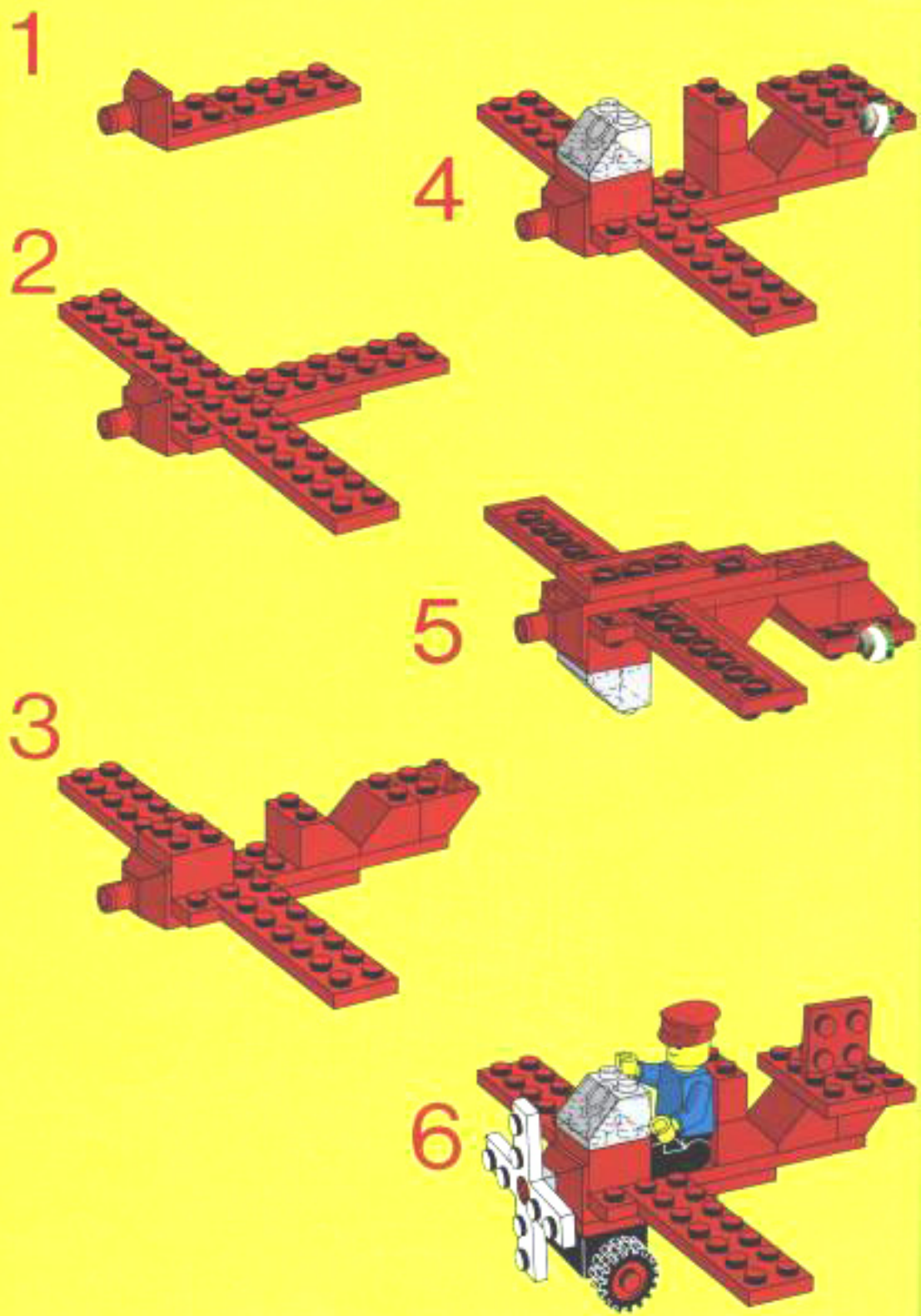
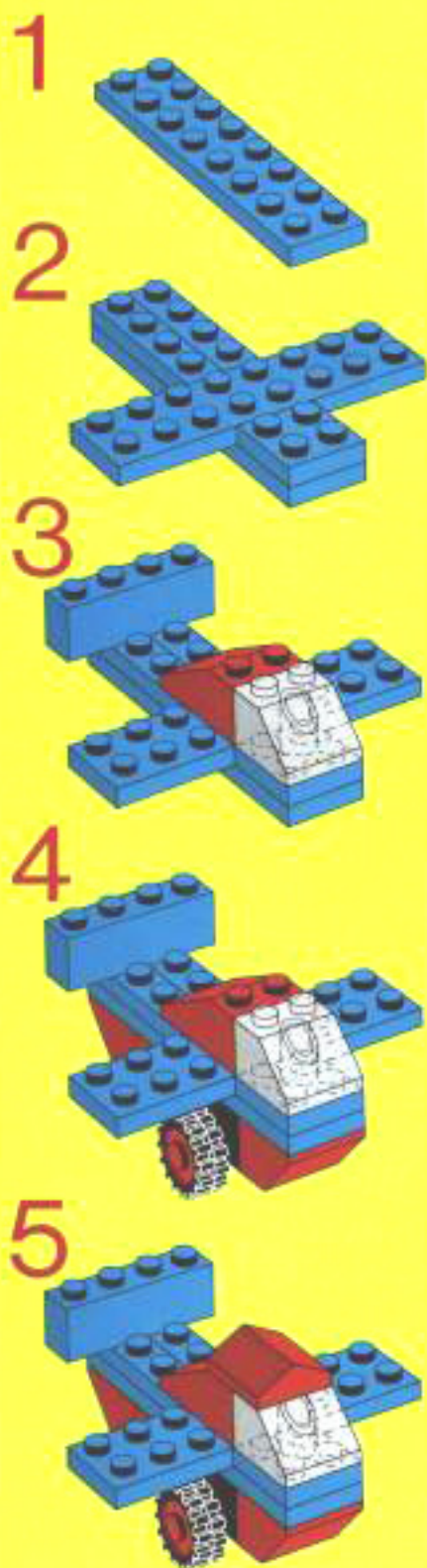

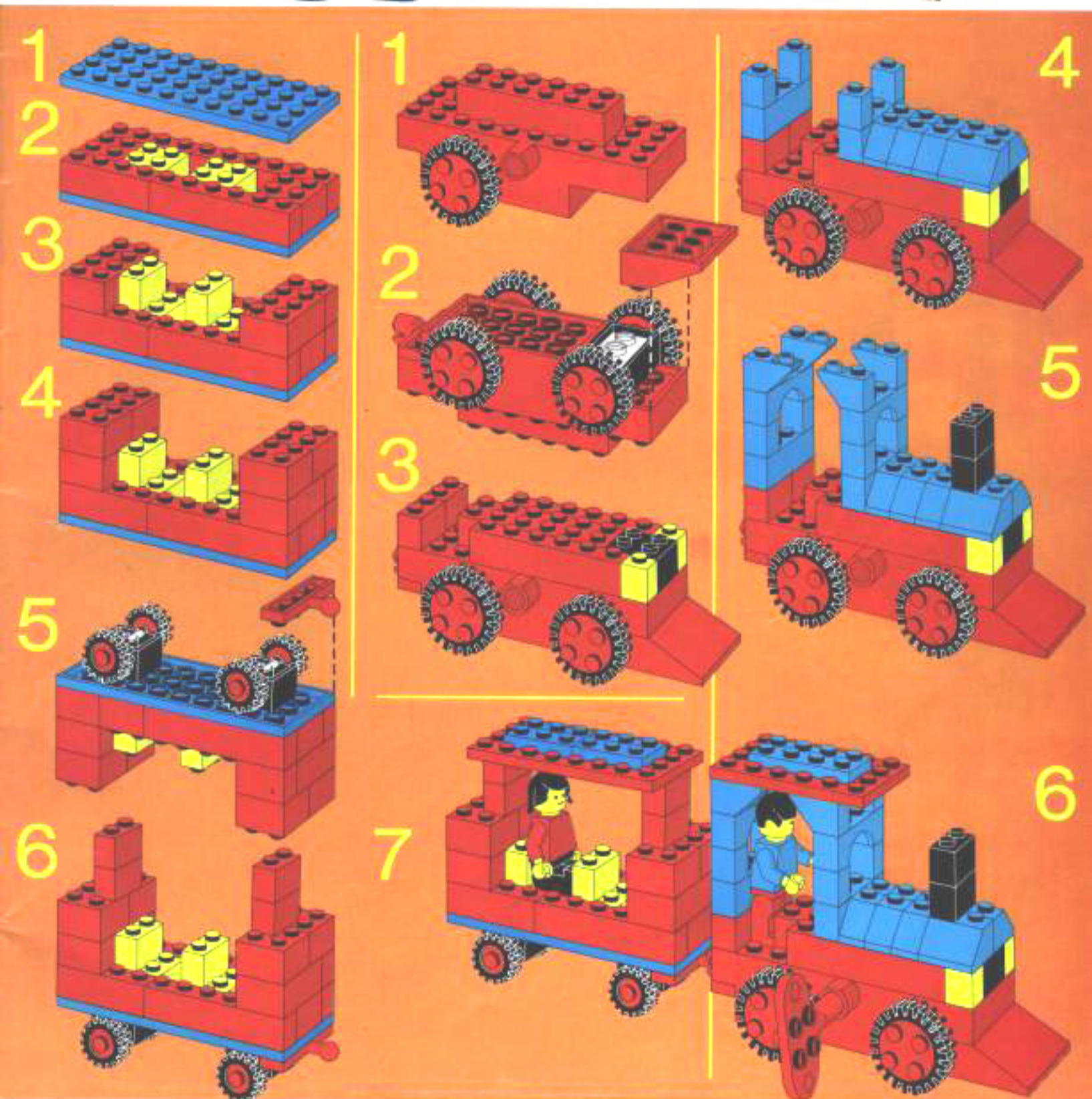

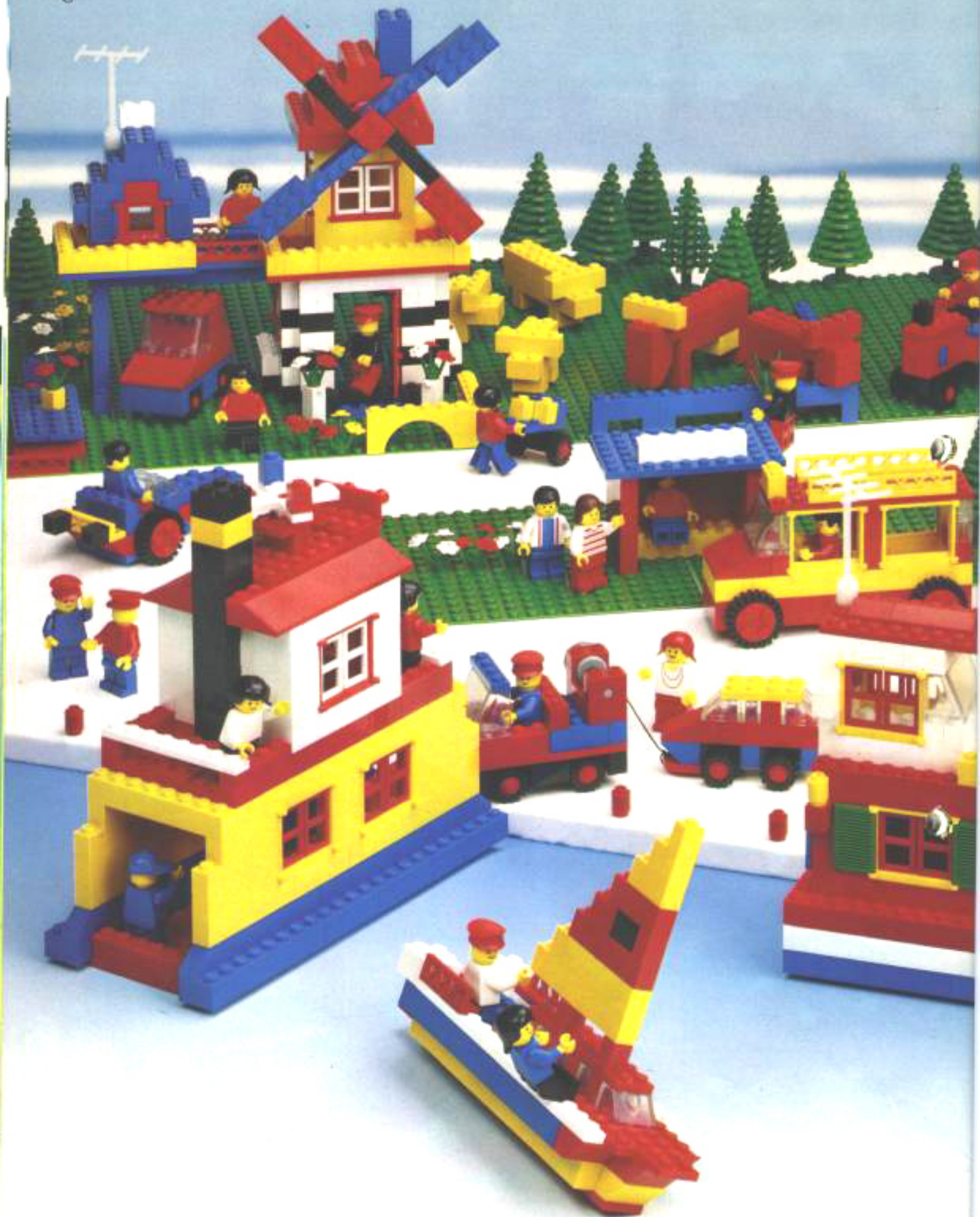

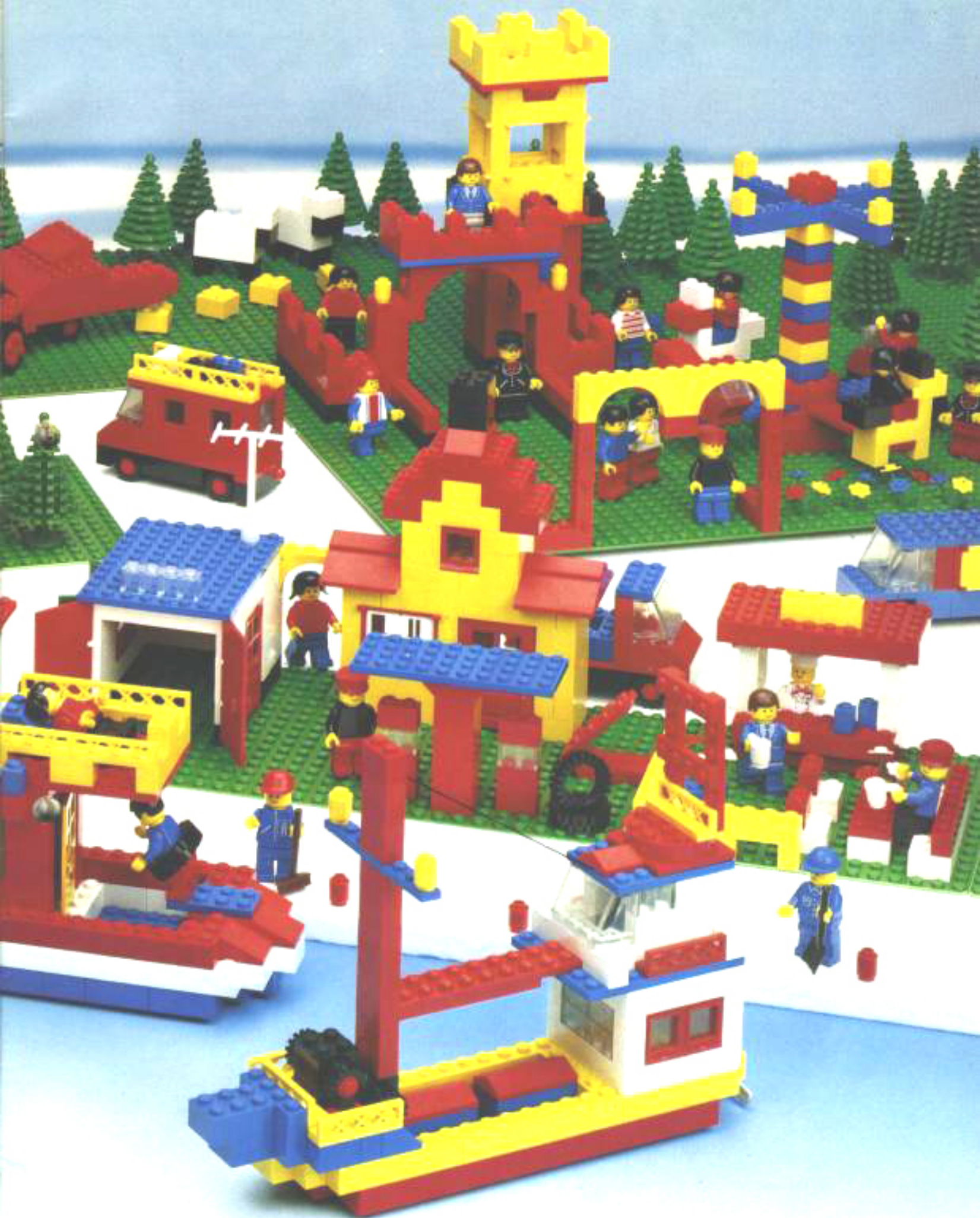



1

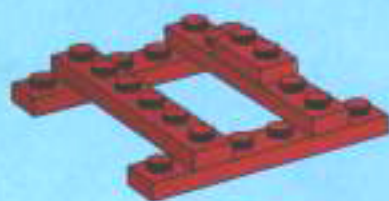

2



3

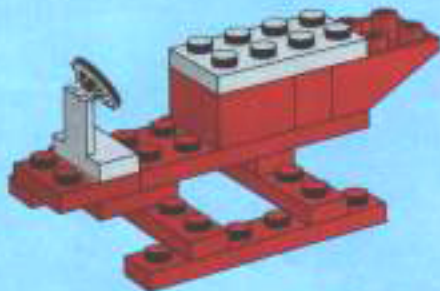

4

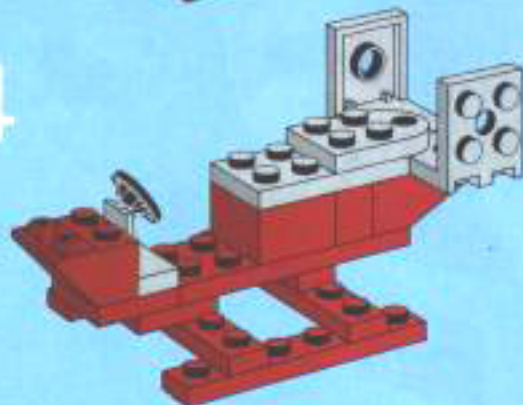

5

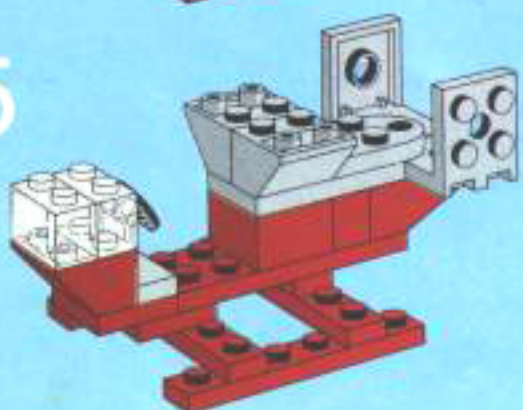

6

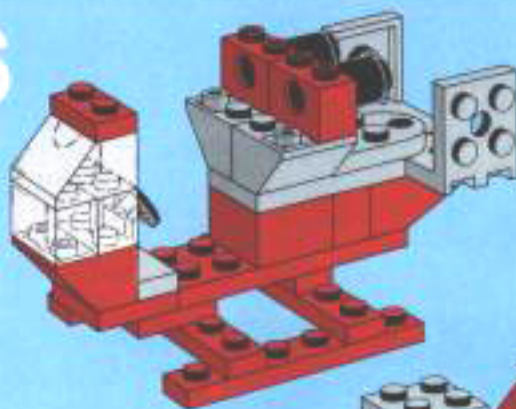

7

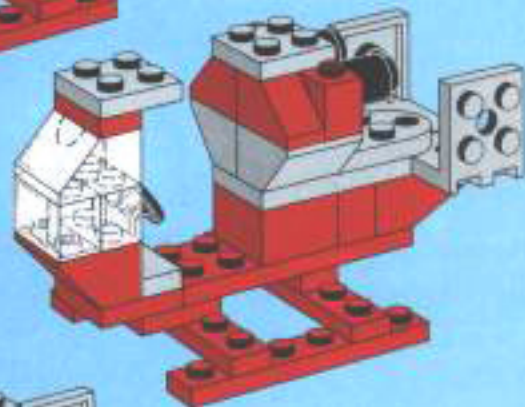

8

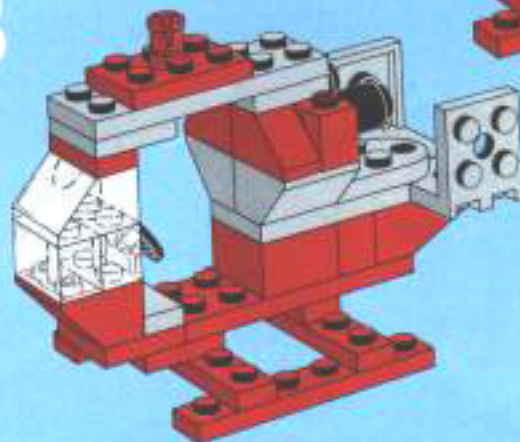

9

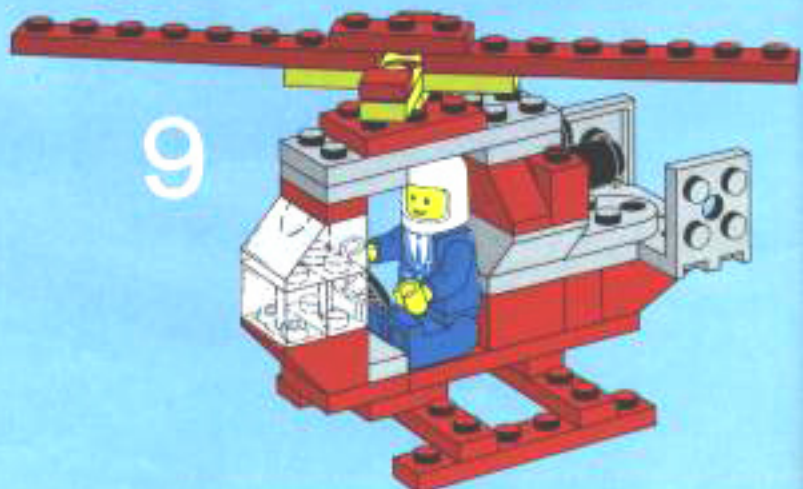

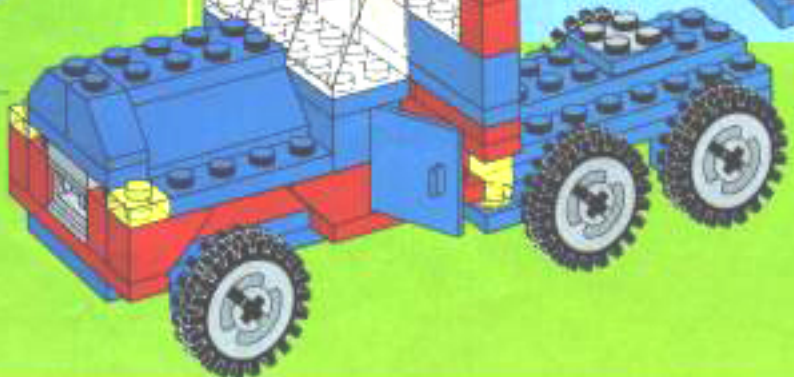
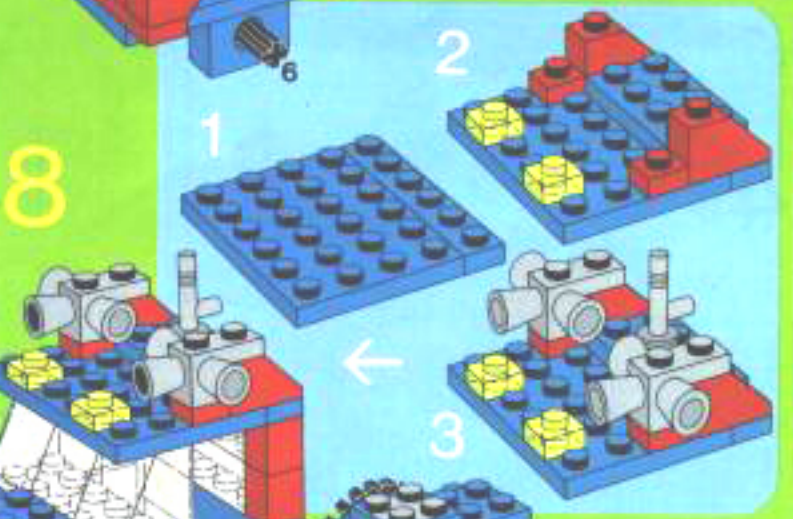
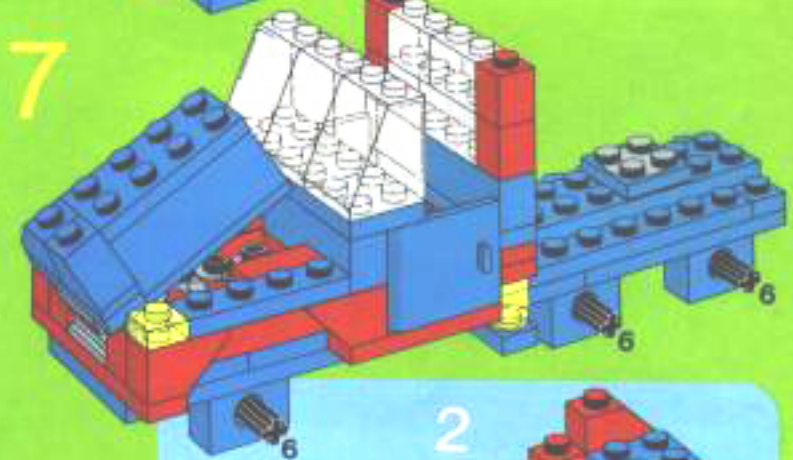
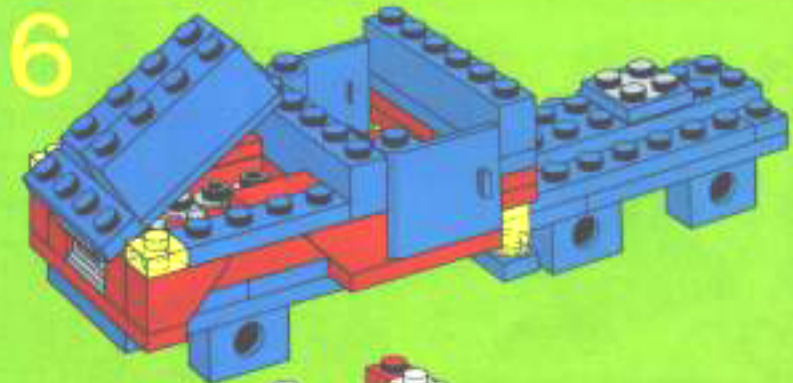
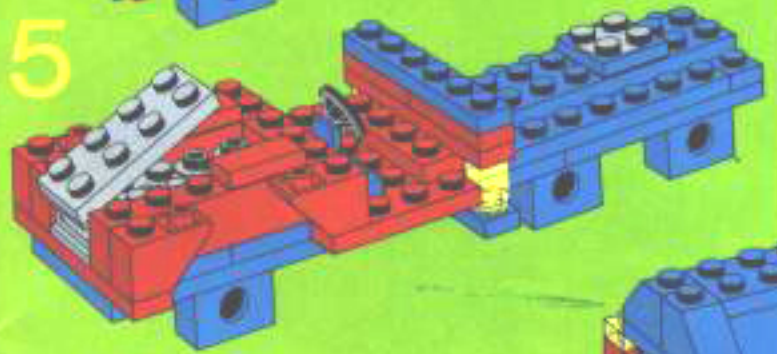
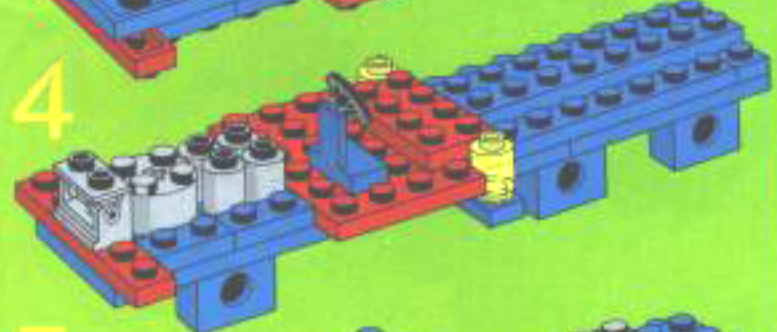
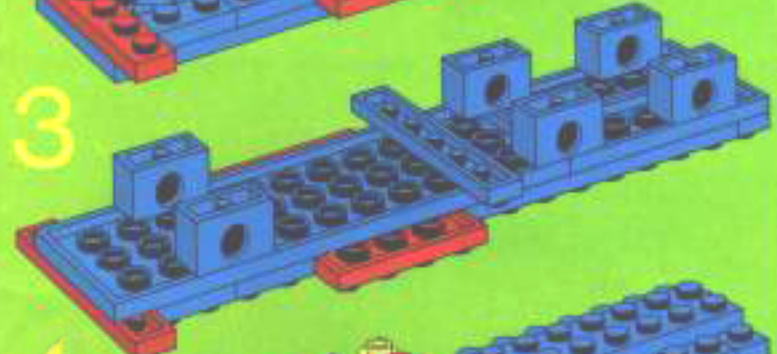
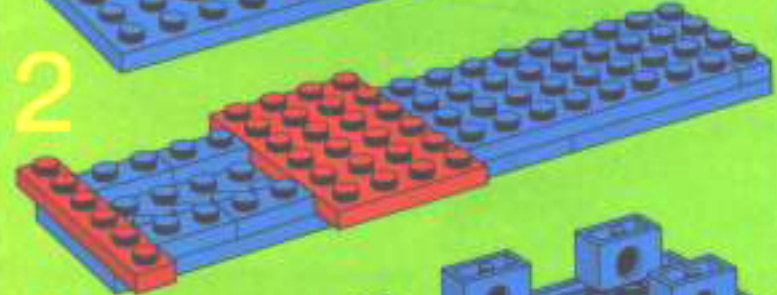
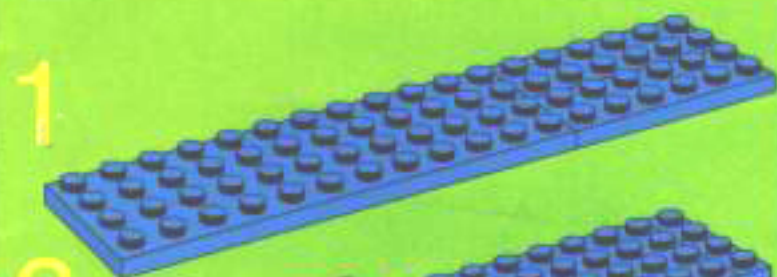



1

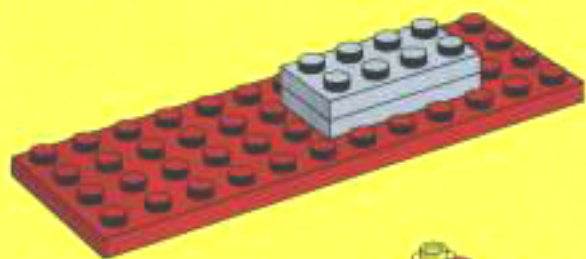

2

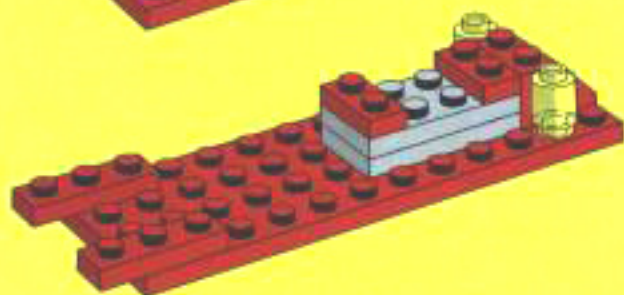

3

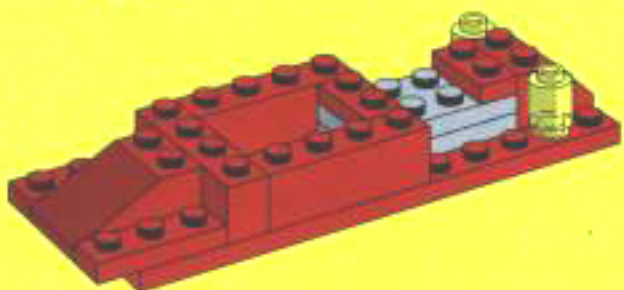

4

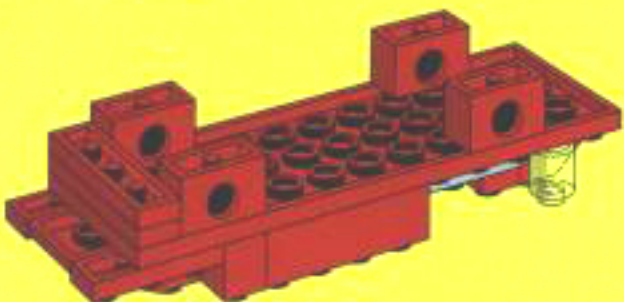

5

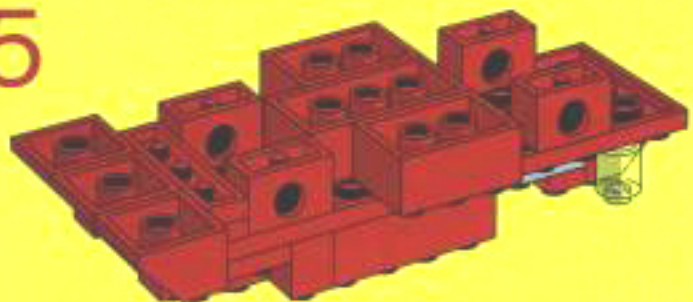

6

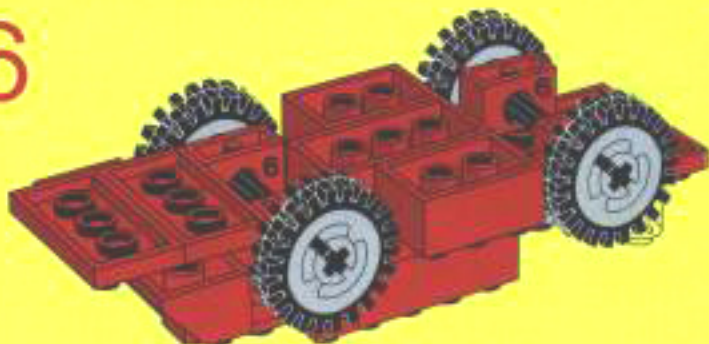

7

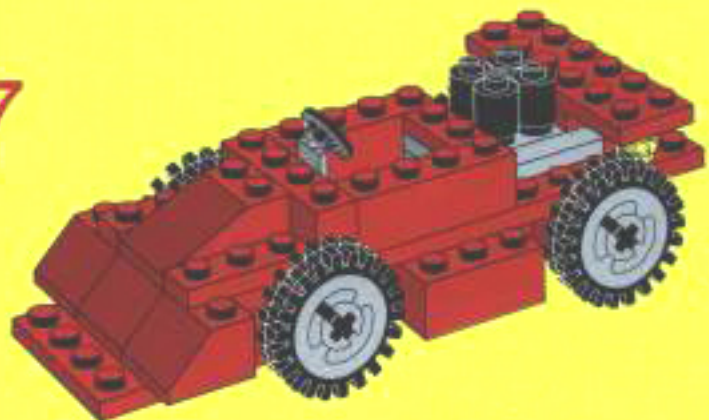

8

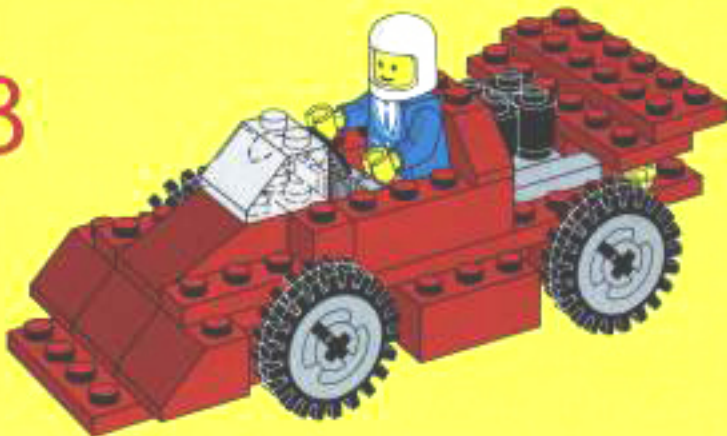

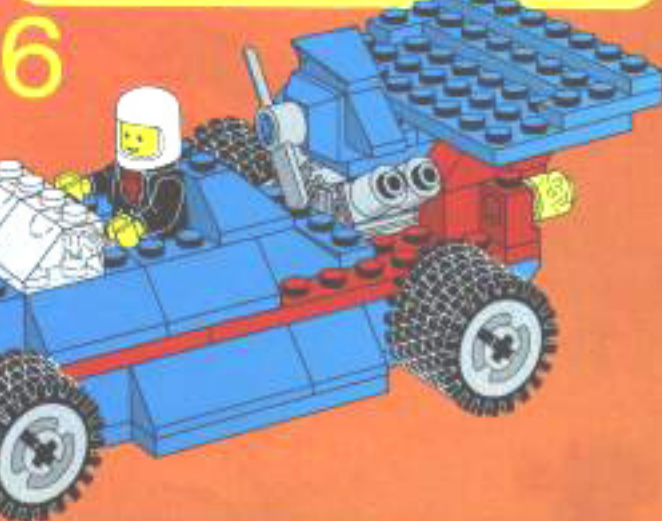
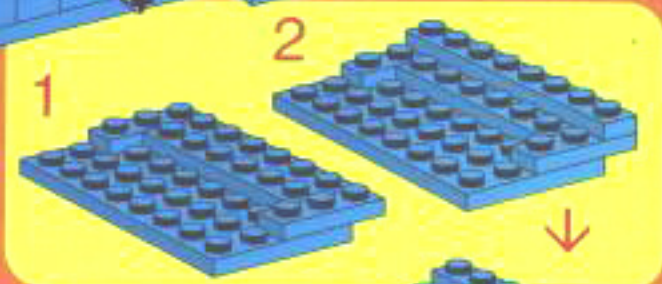
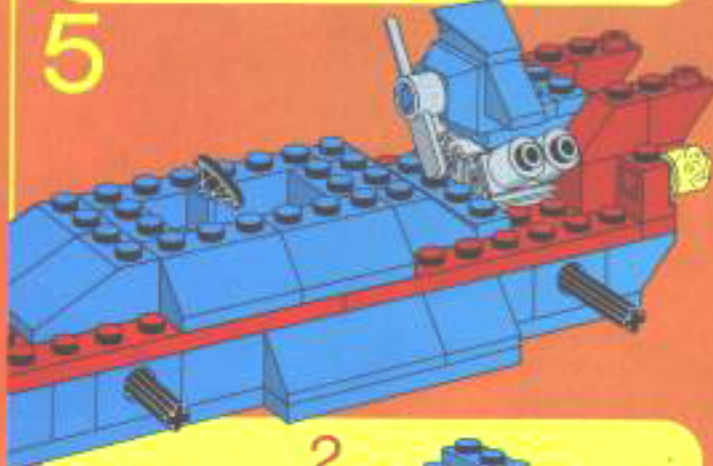
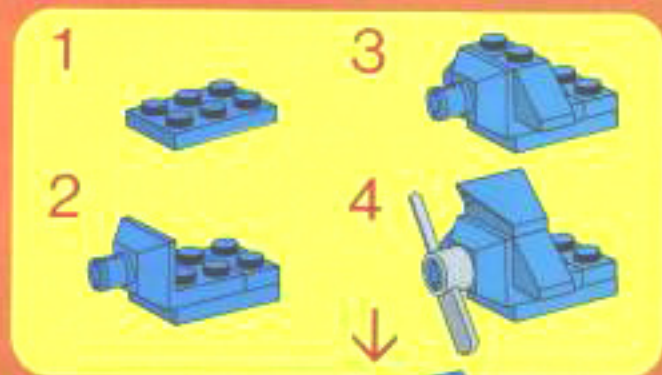
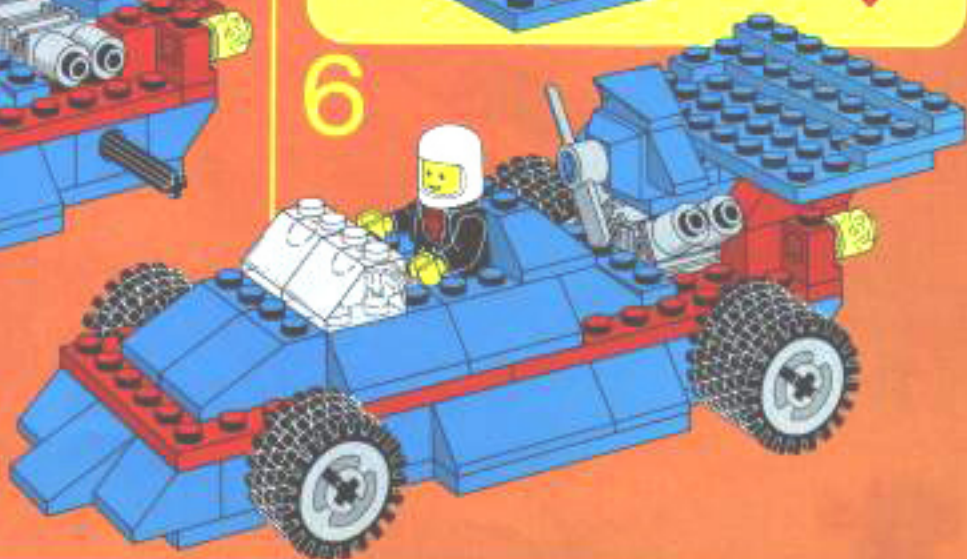
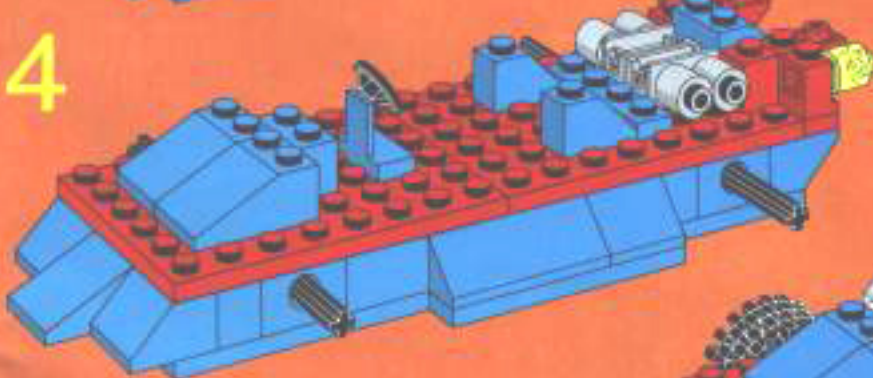
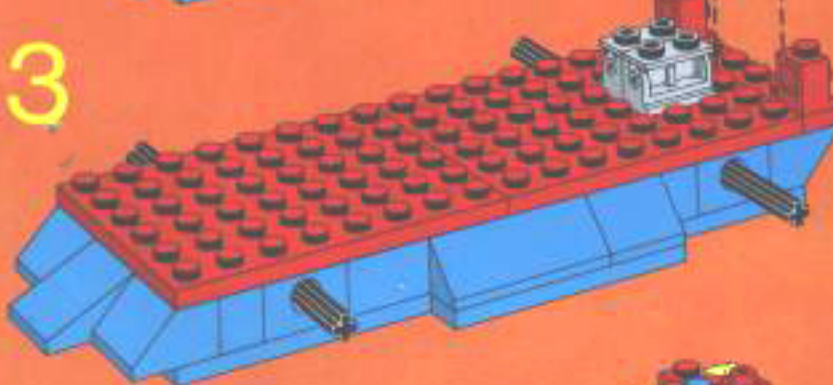
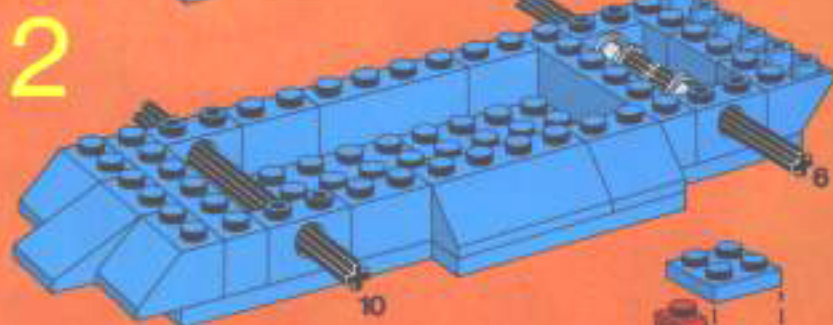
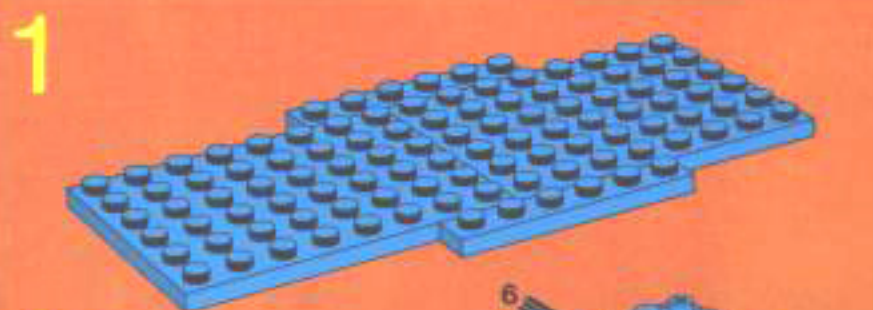





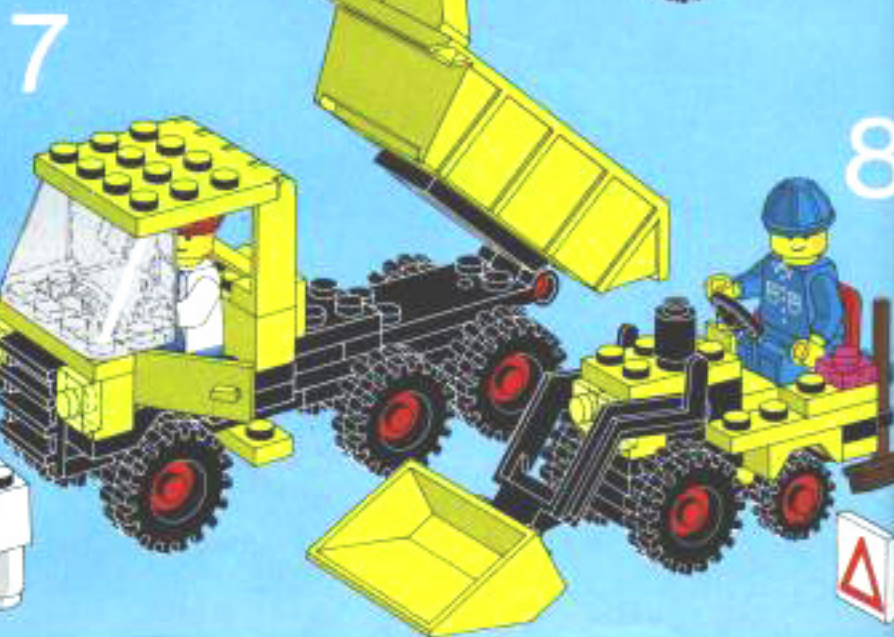
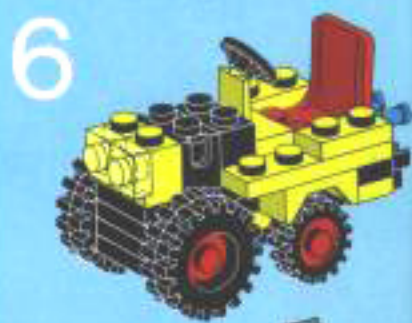
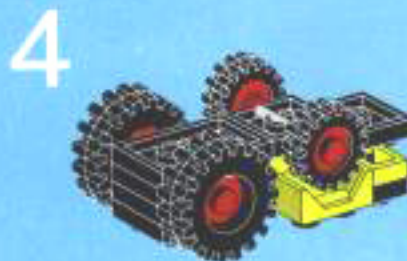
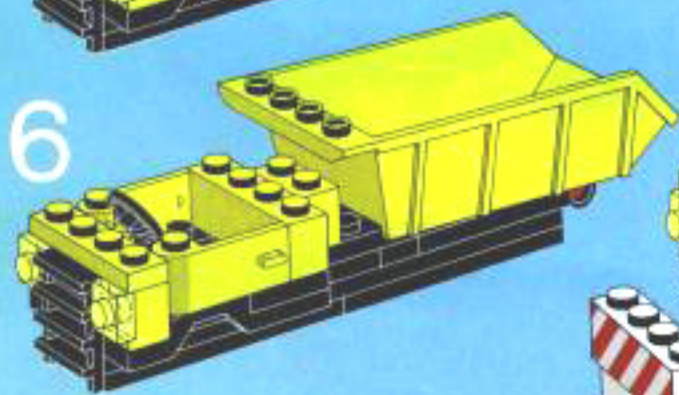
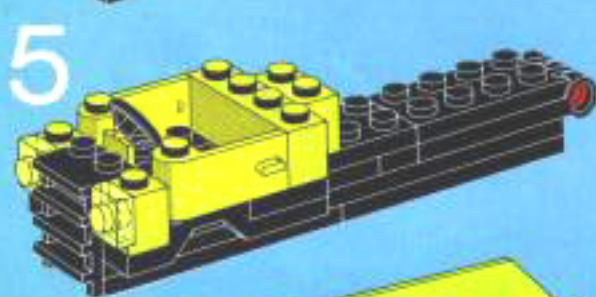
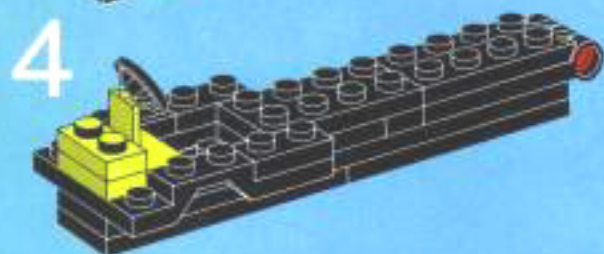
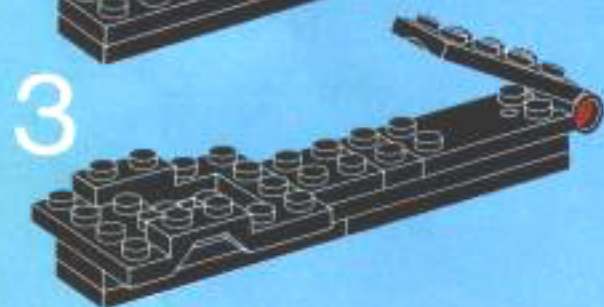
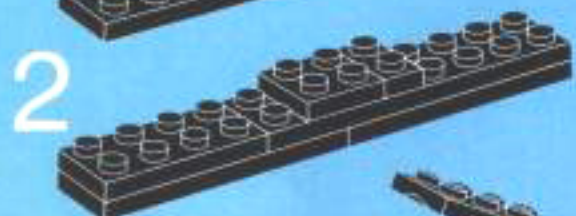
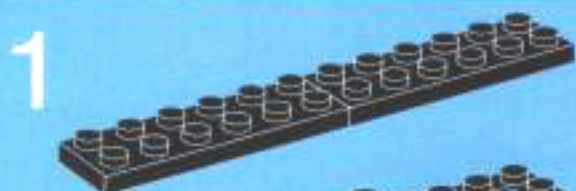

8



1

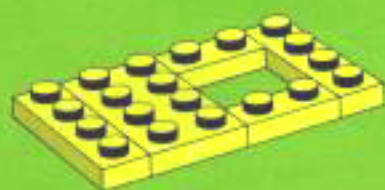

2

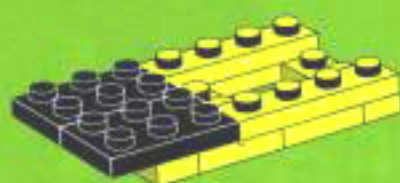

3

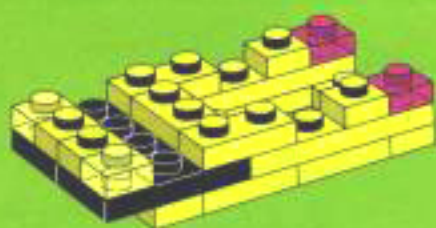

4

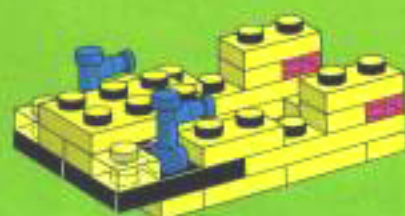

3



5

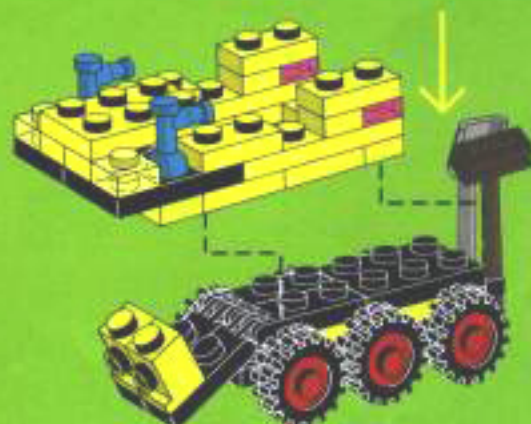

6

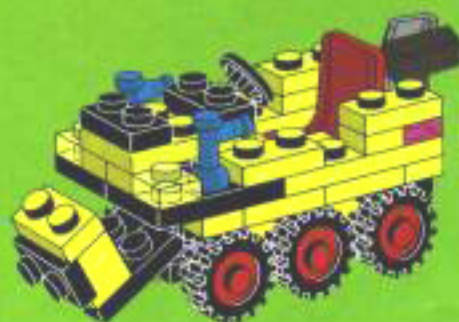

7



1



2



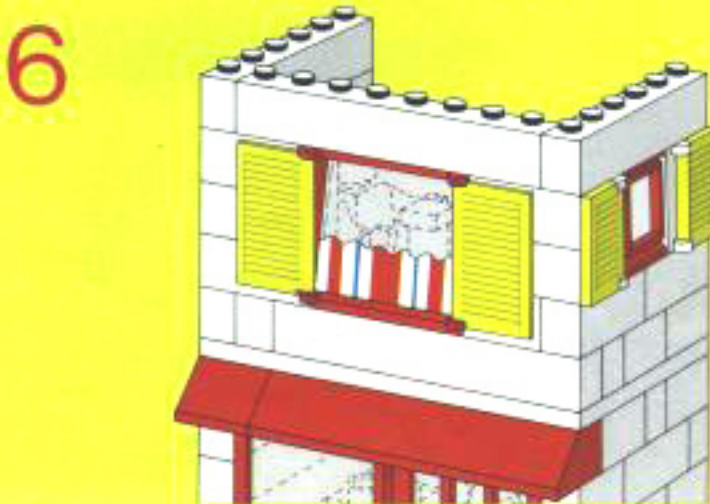
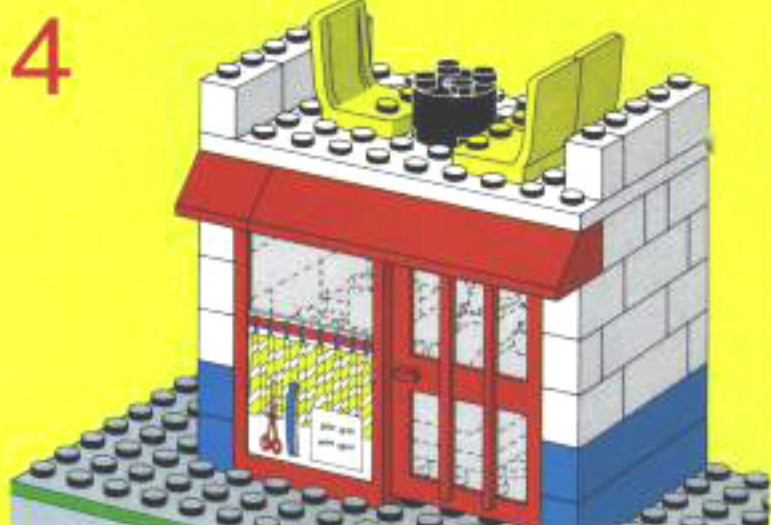
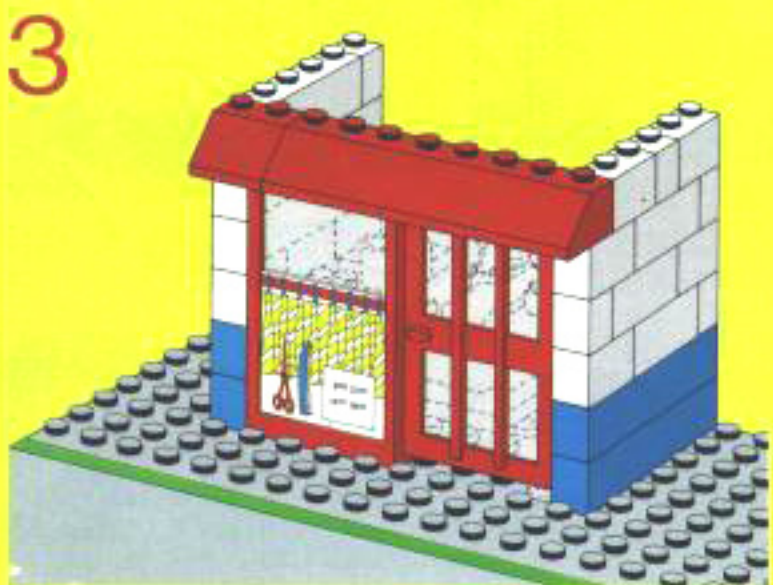
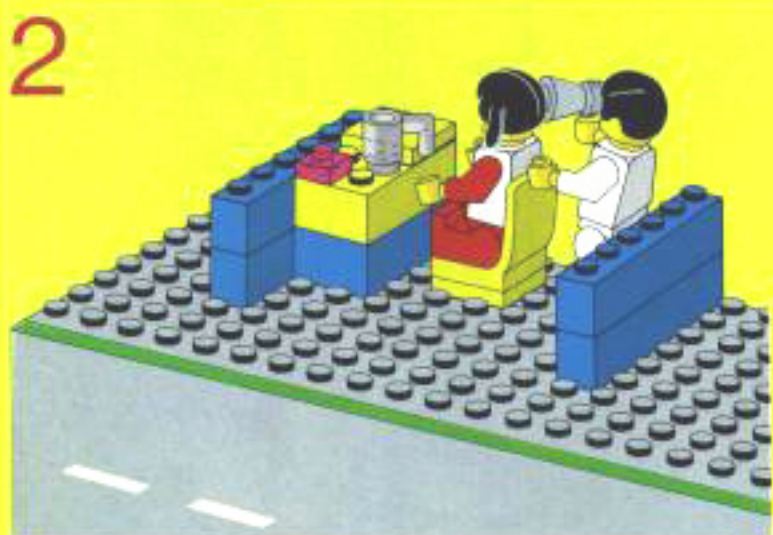
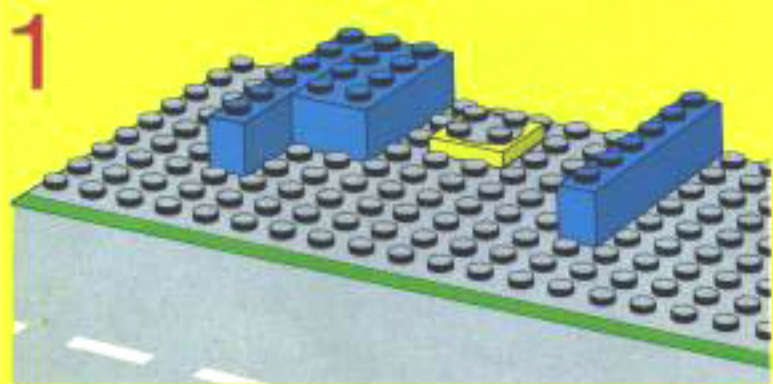



7

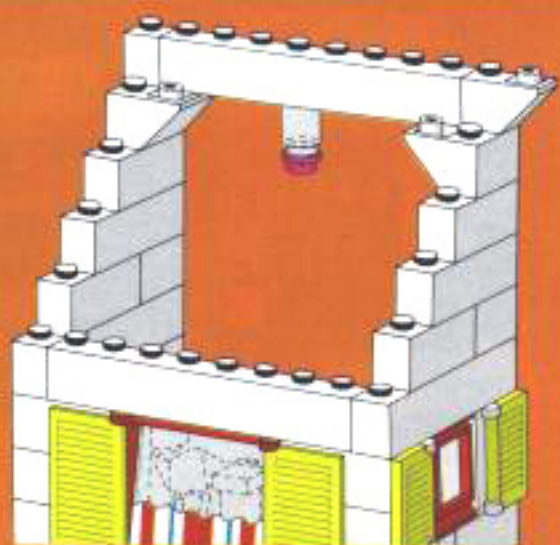

8



9







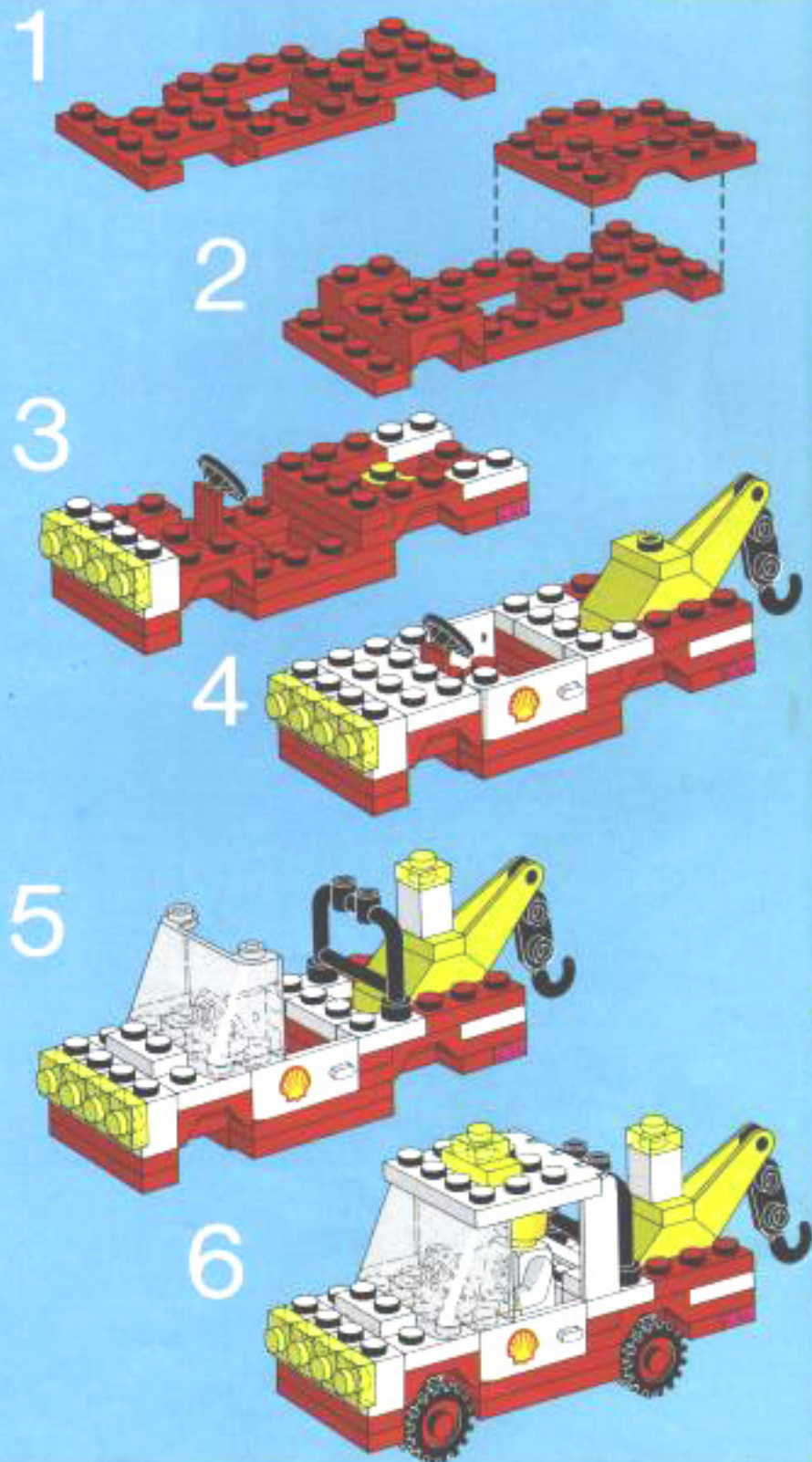
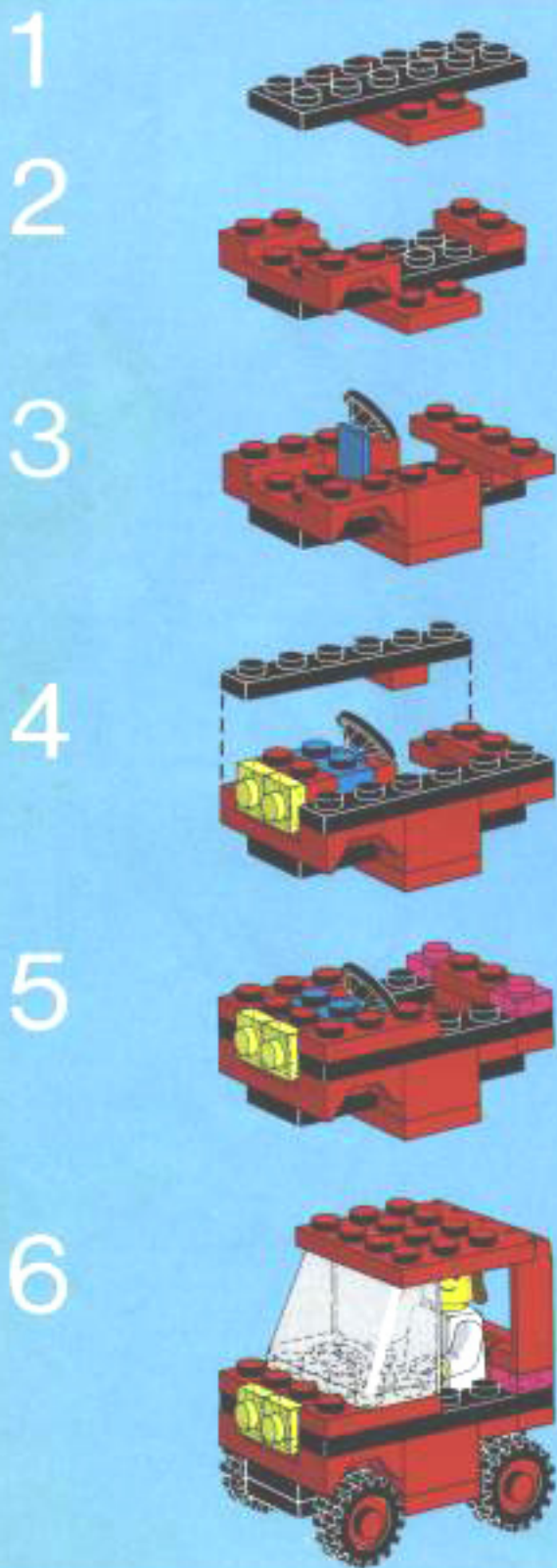



1



2



3



4

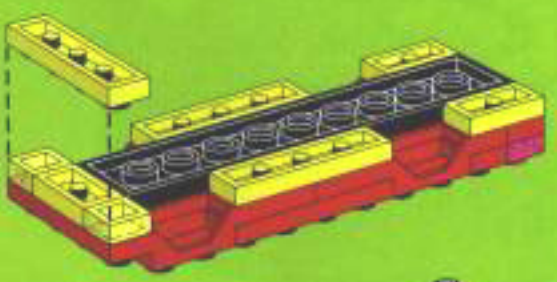

5

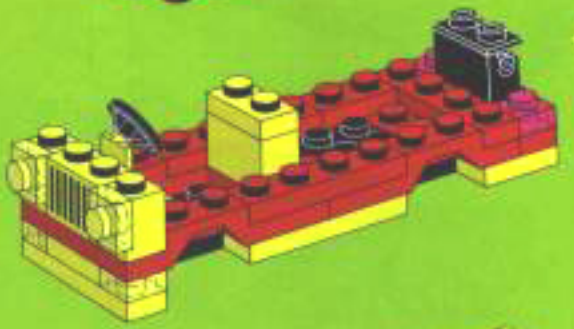

6

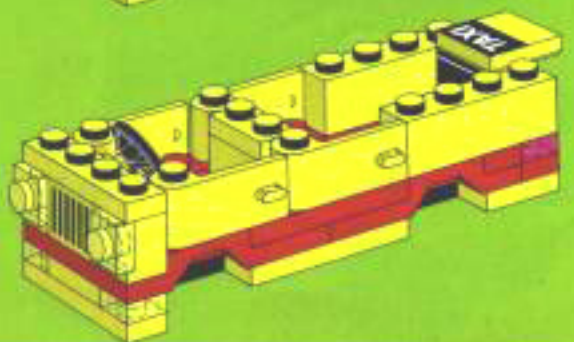

7

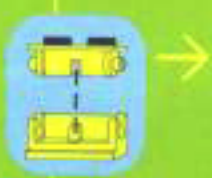
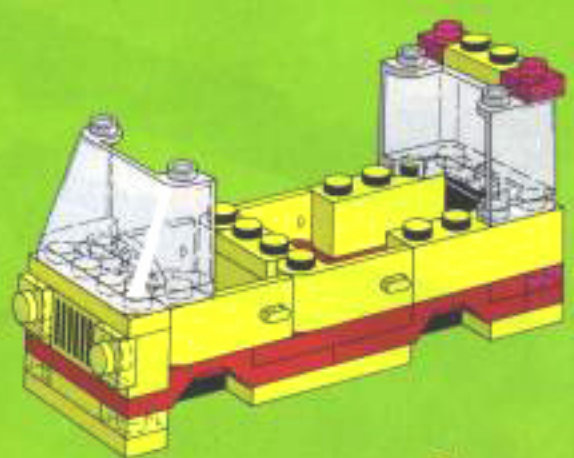

8

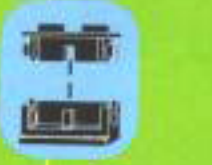
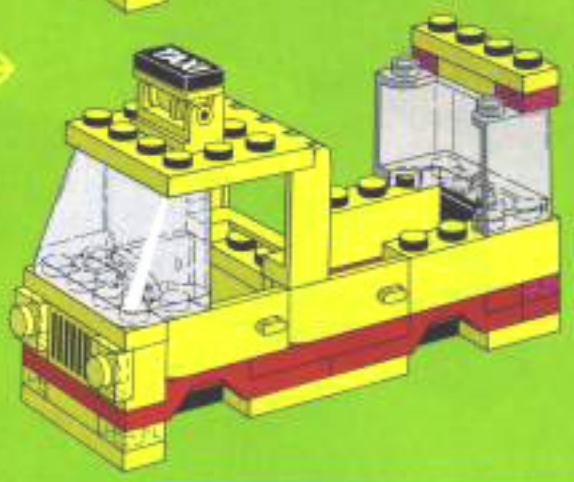

9

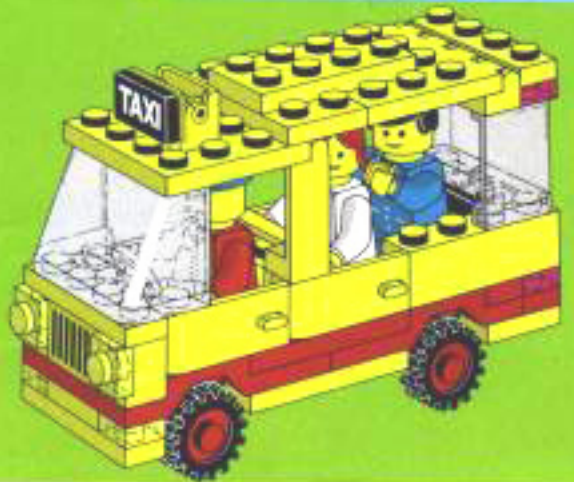
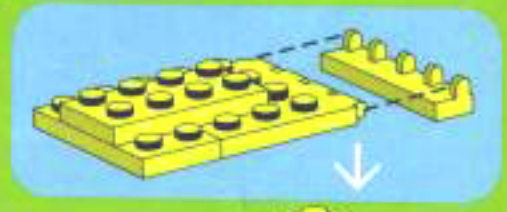



1

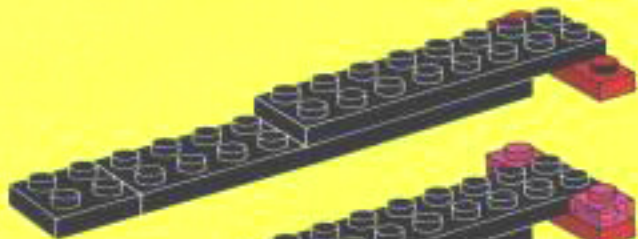

2



3

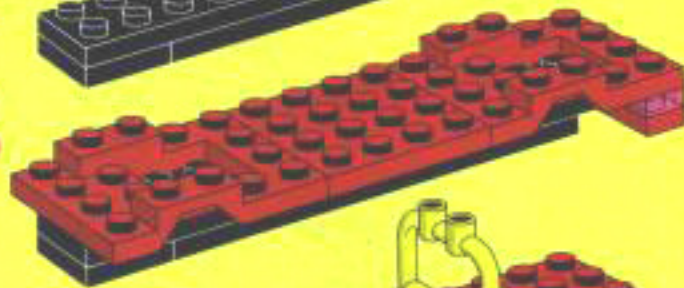

4



5

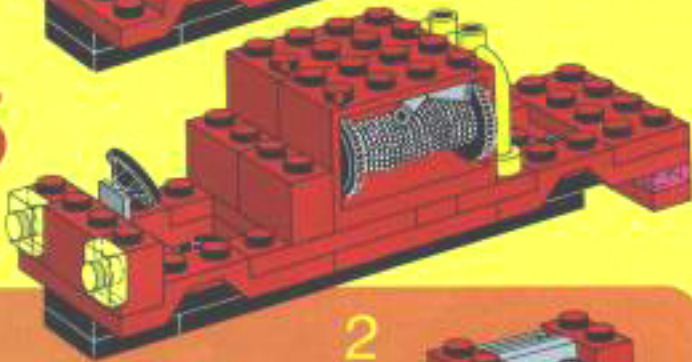

2



1



3



6

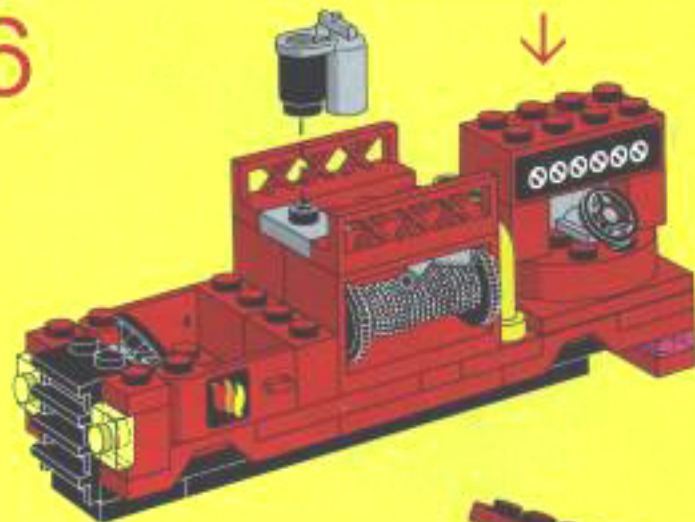

7

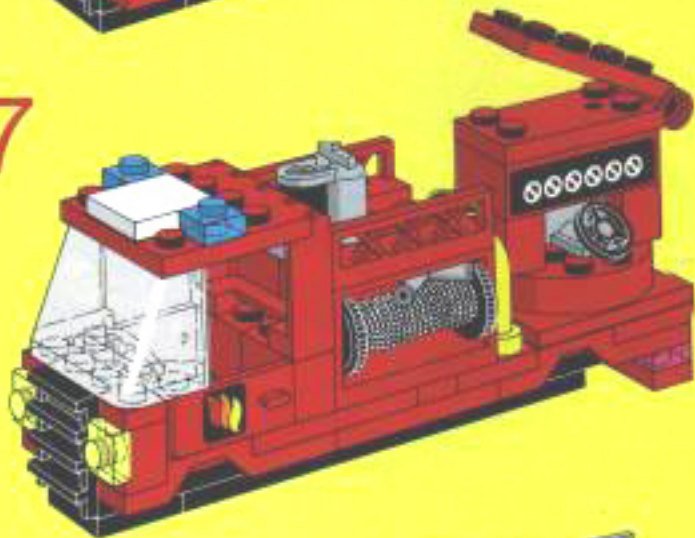

8

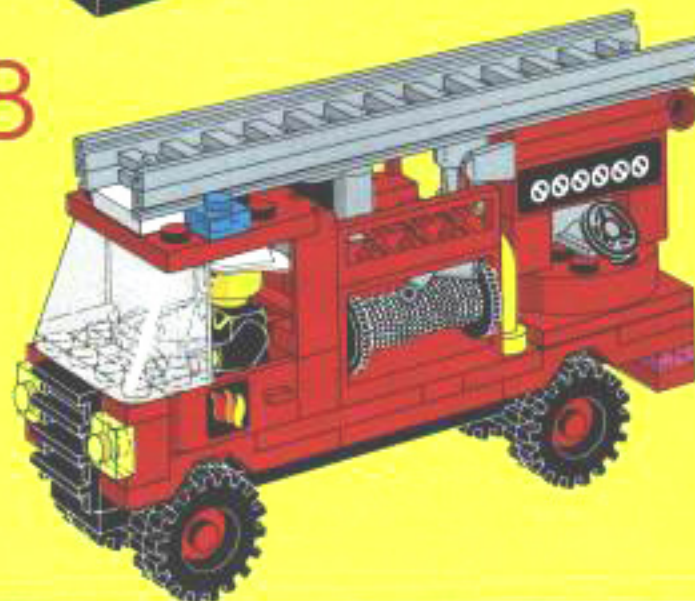

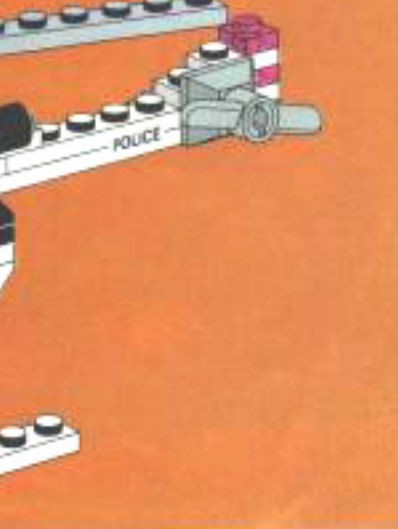
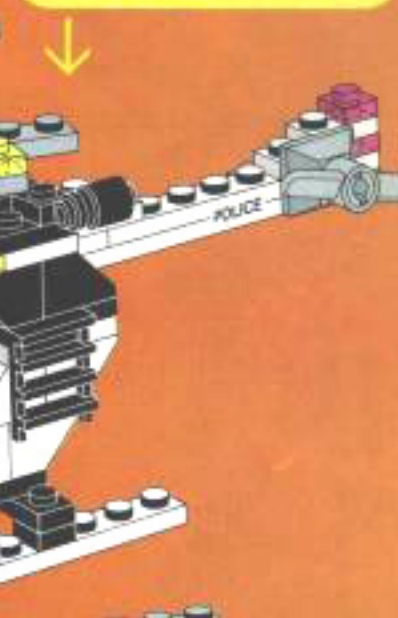
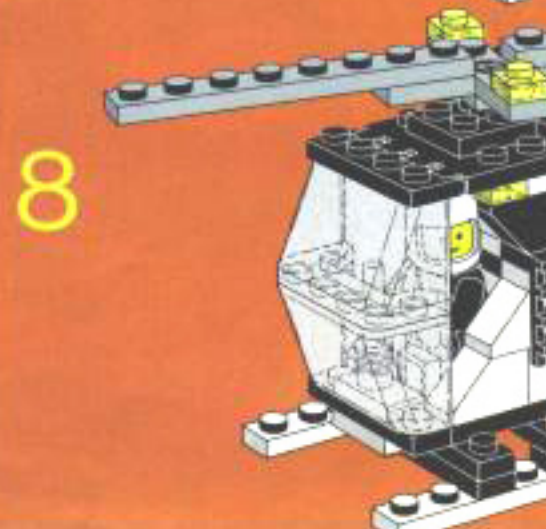
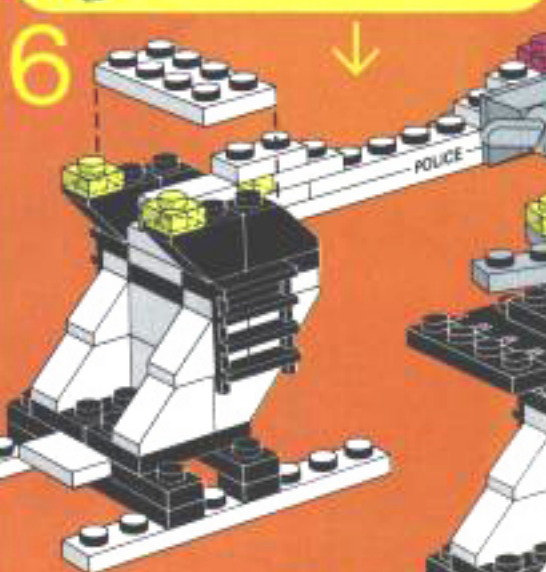
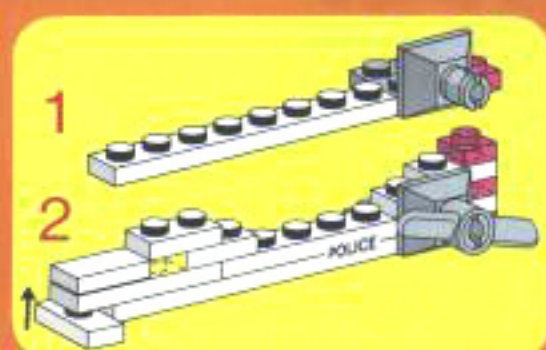
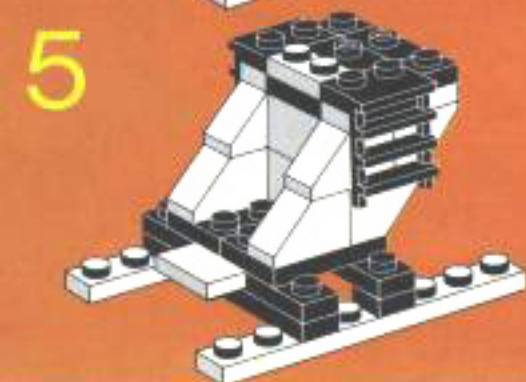
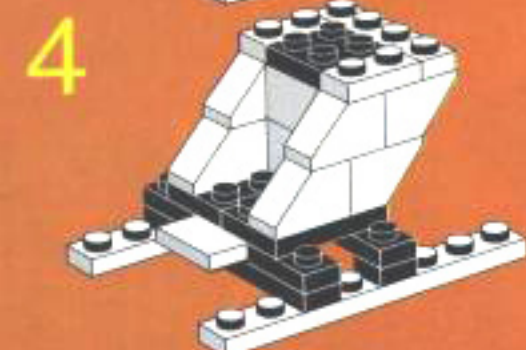
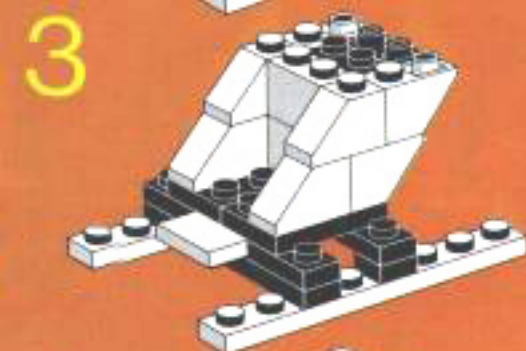
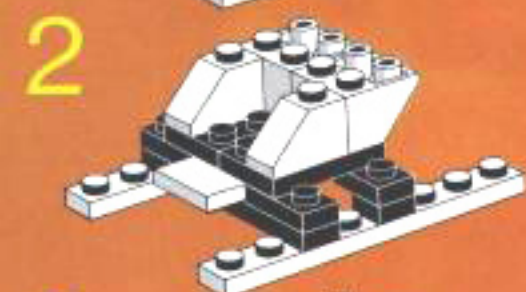
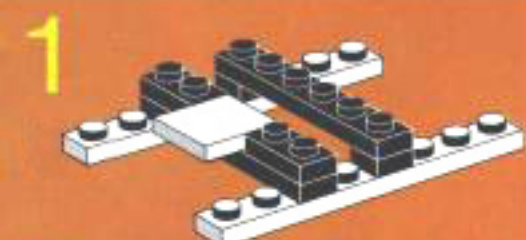





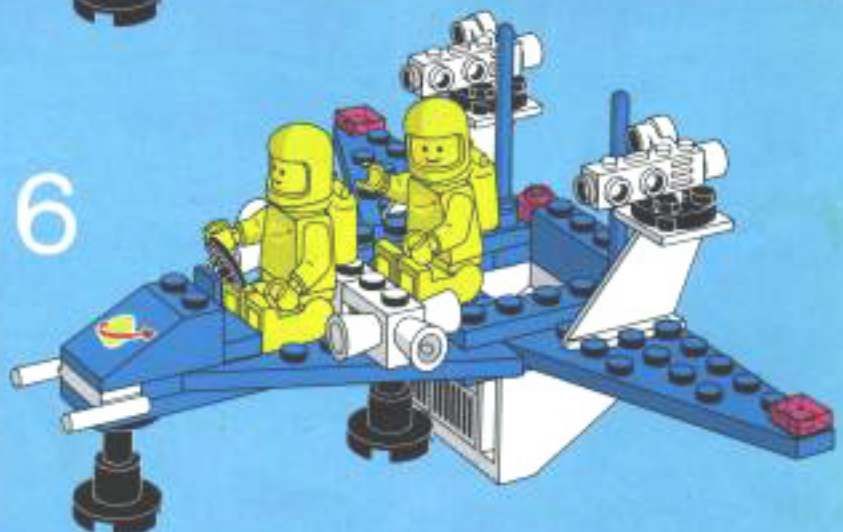
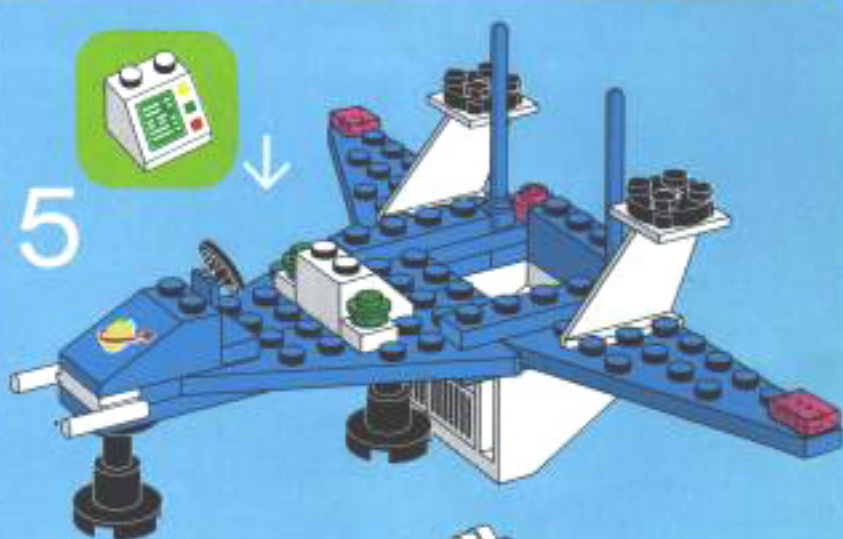
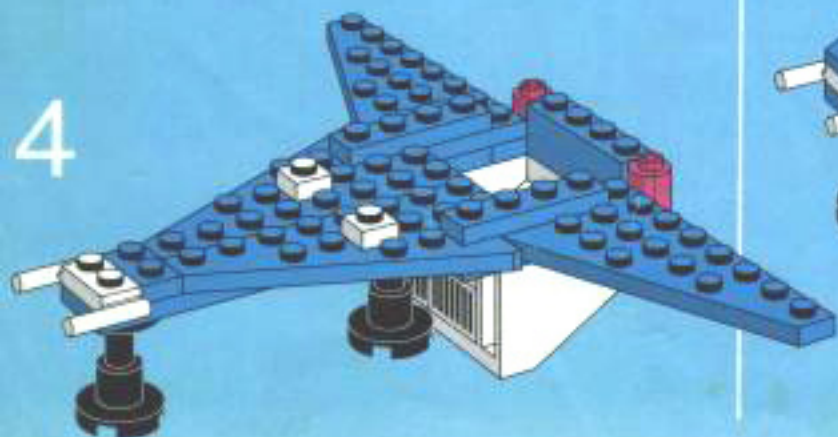
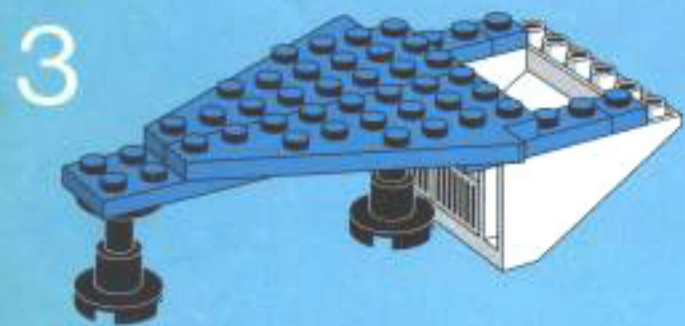
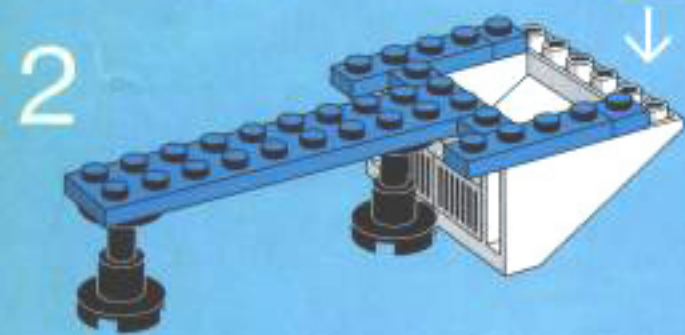
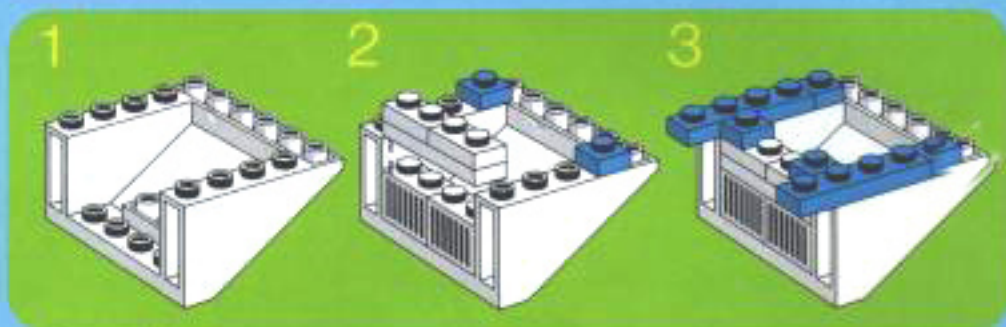
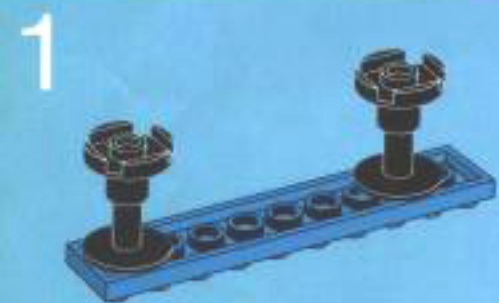
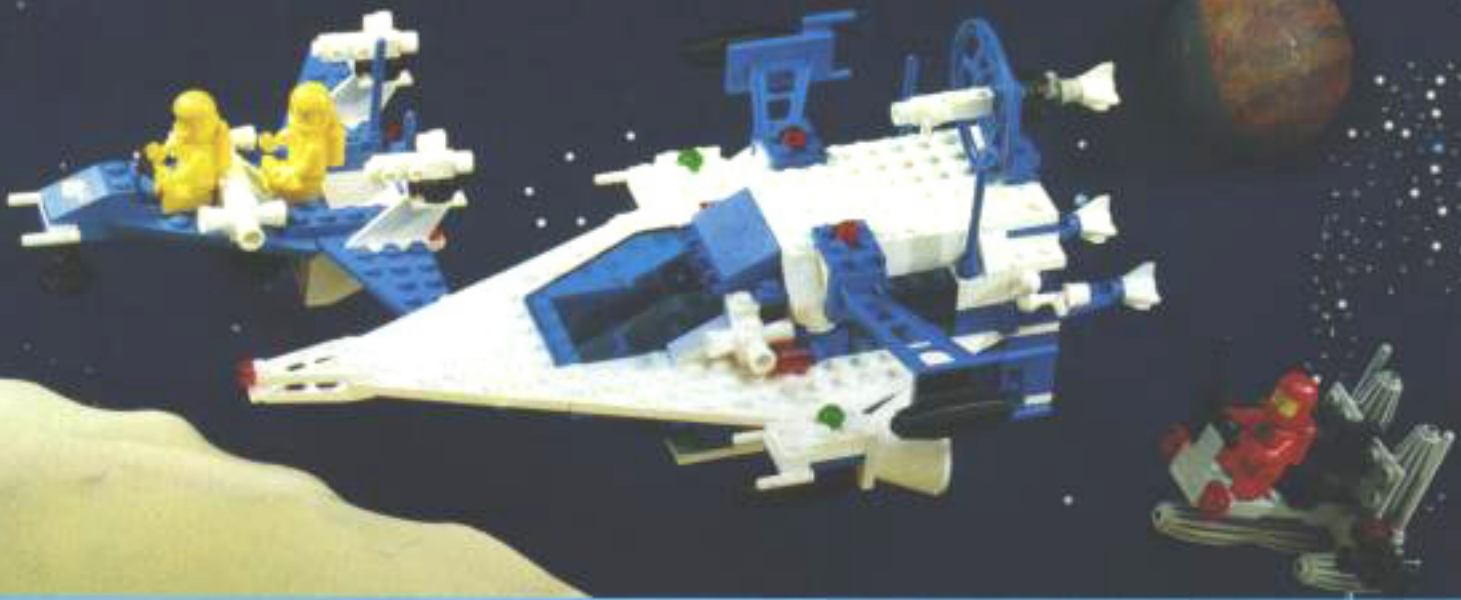

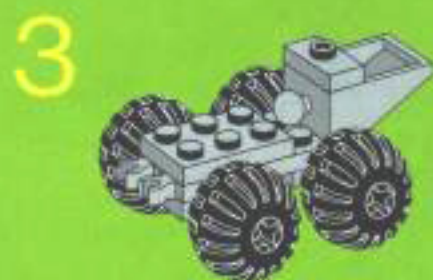
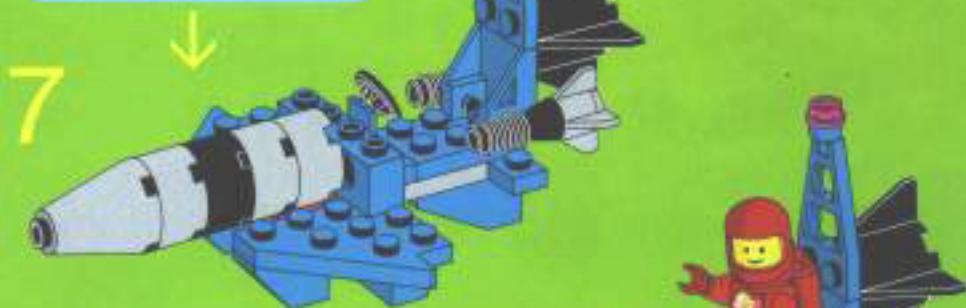
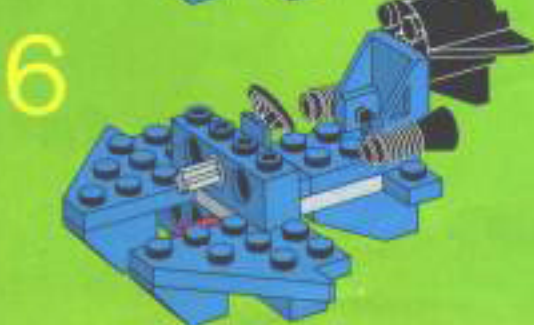
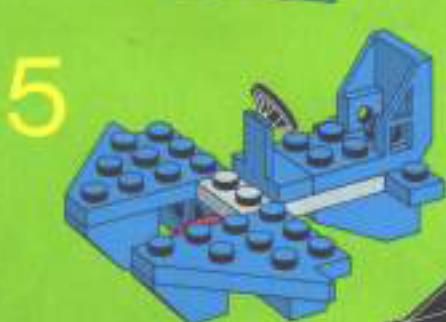
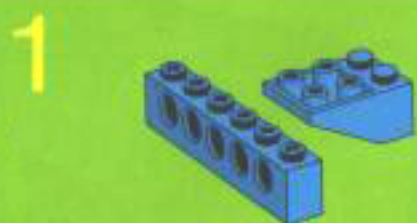
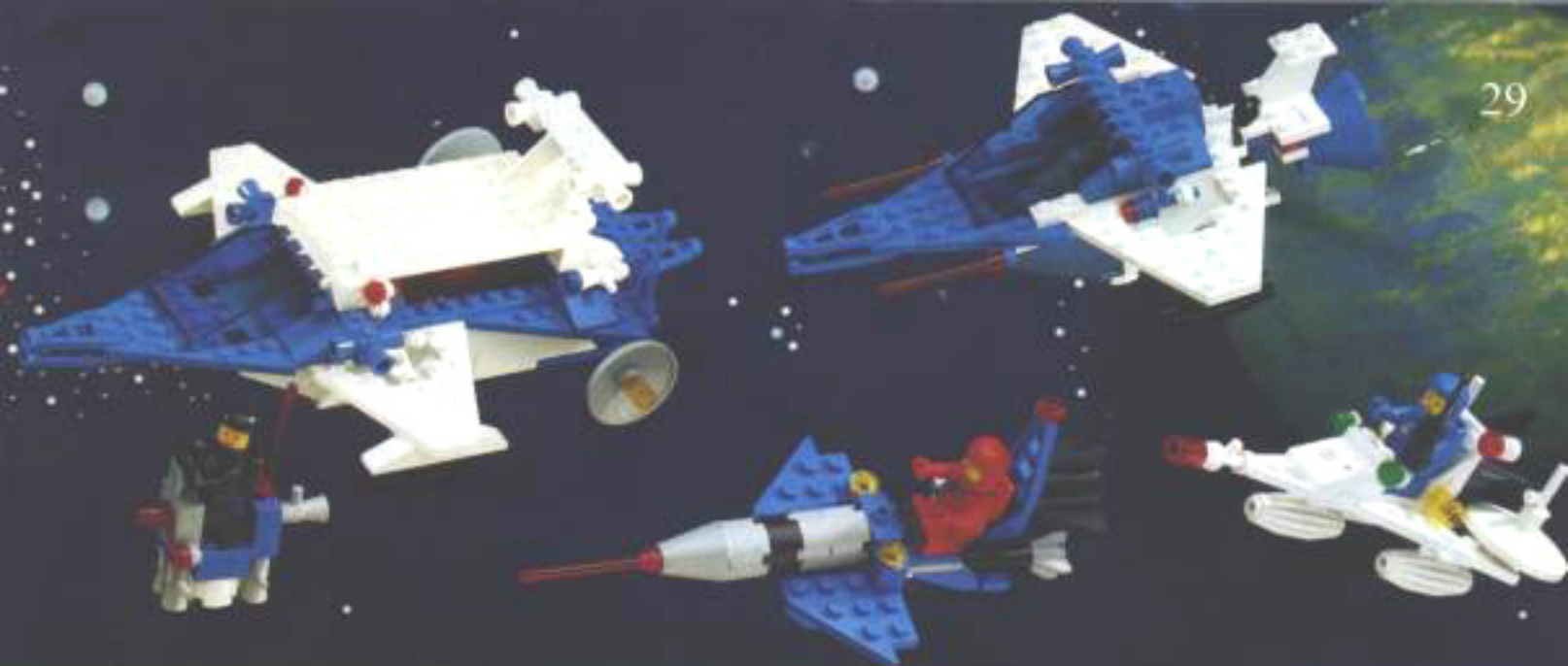

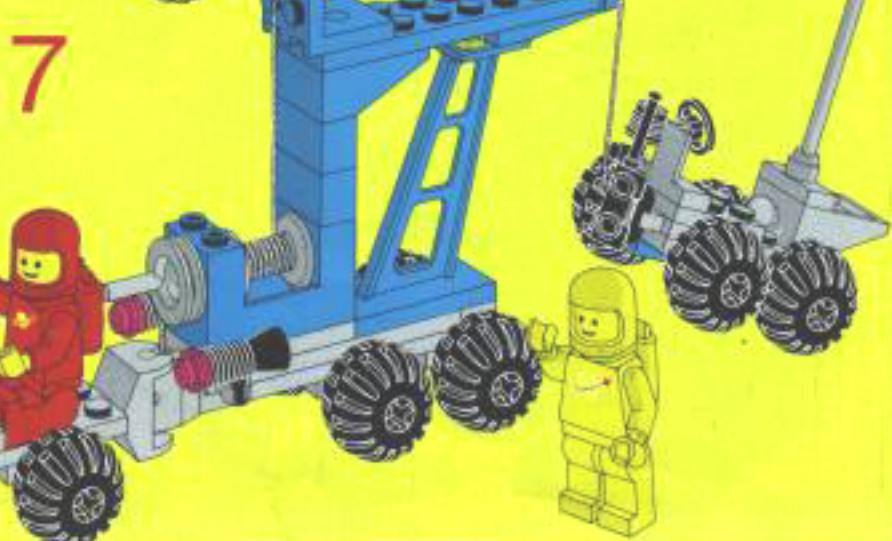
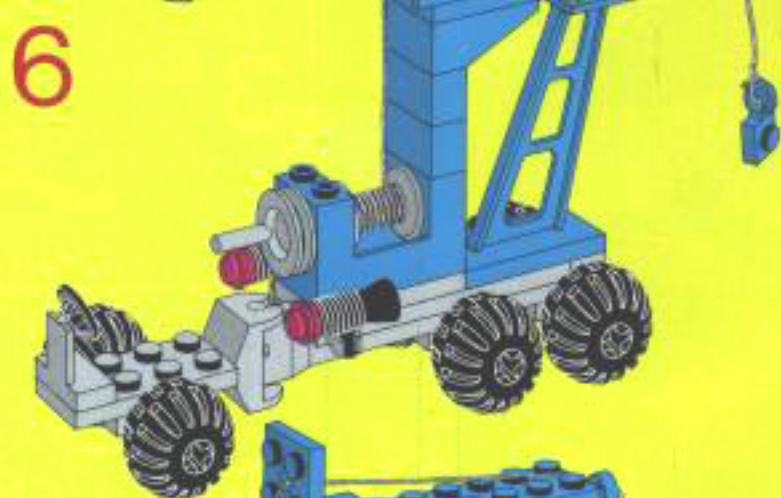
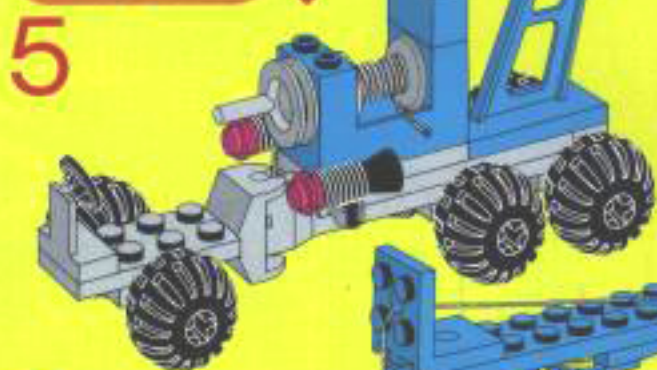
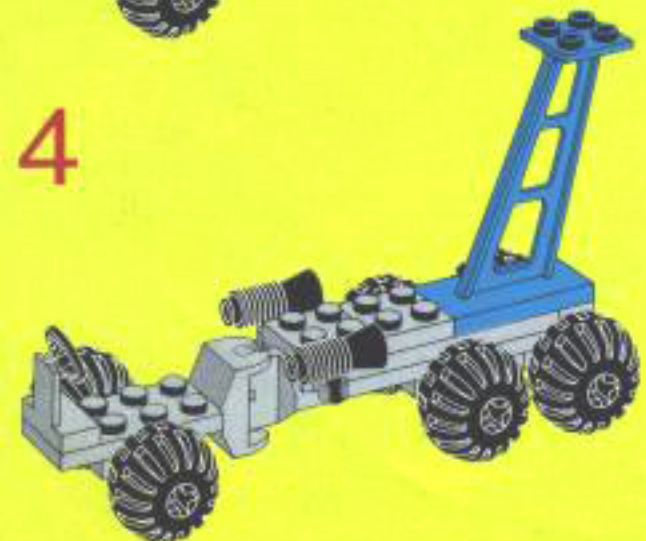
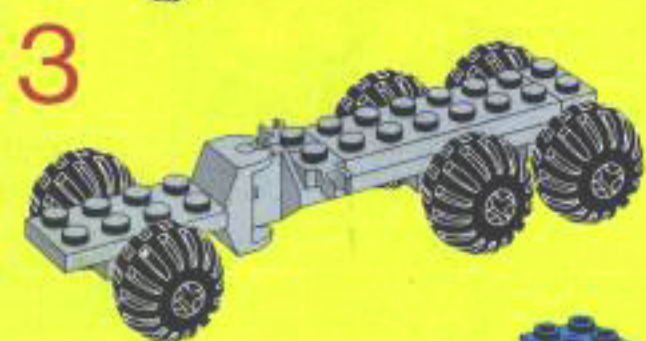
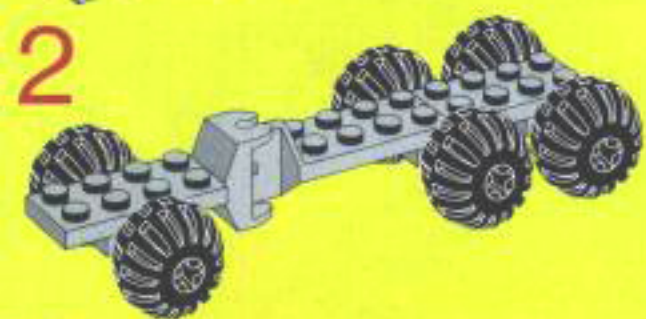
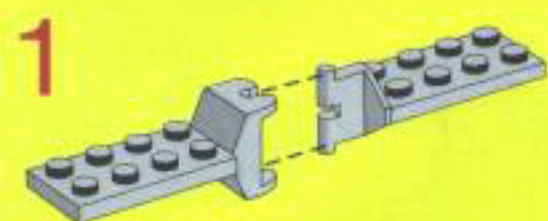

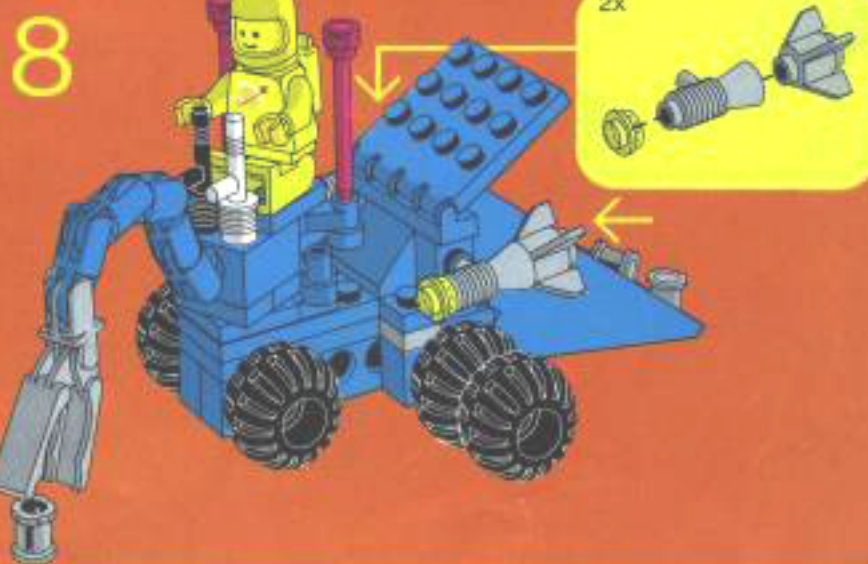
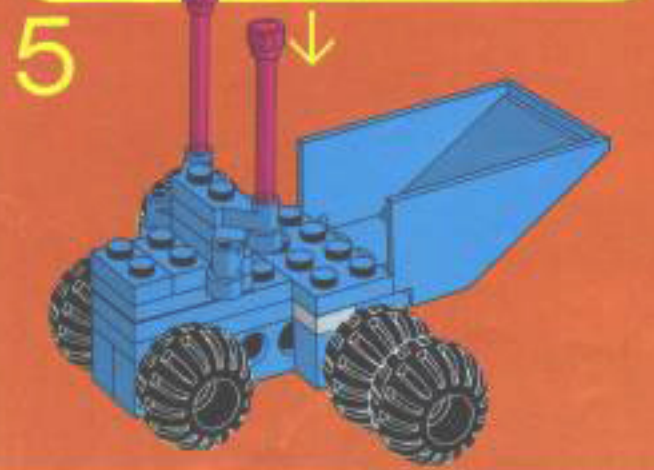
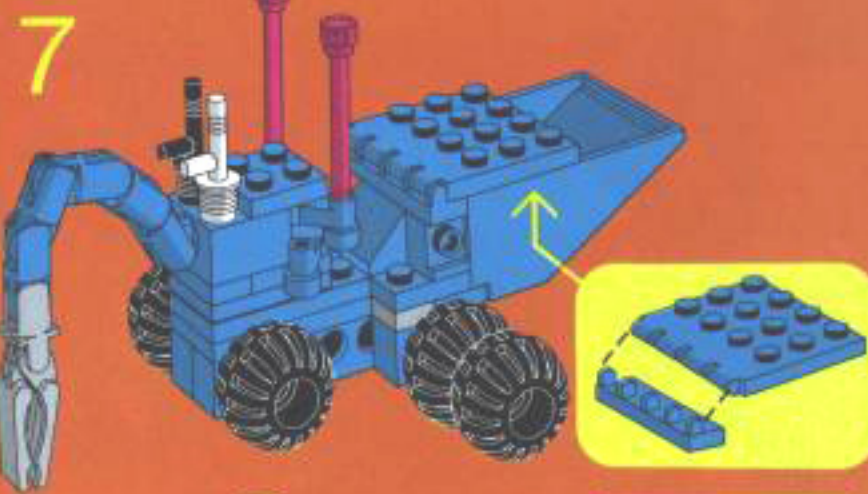
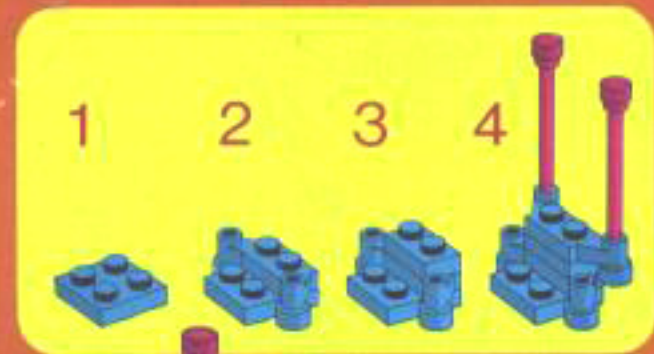
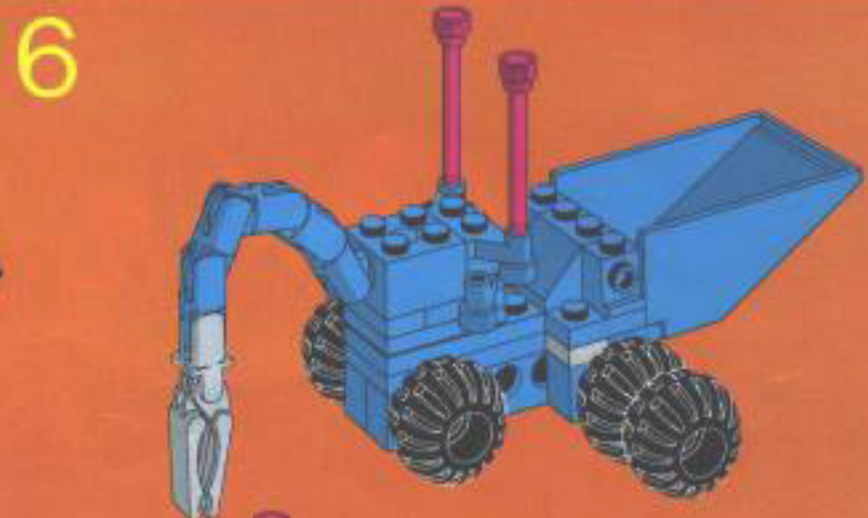
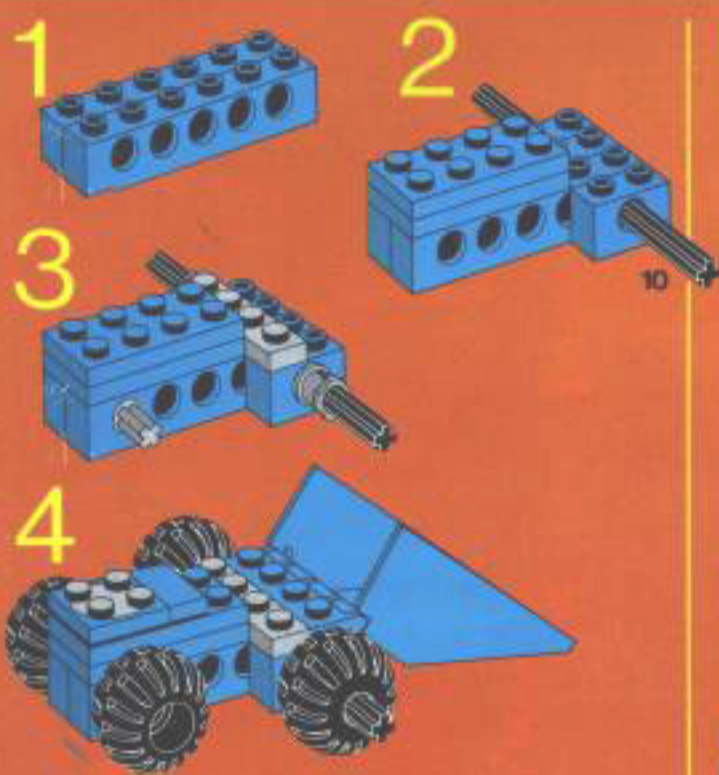





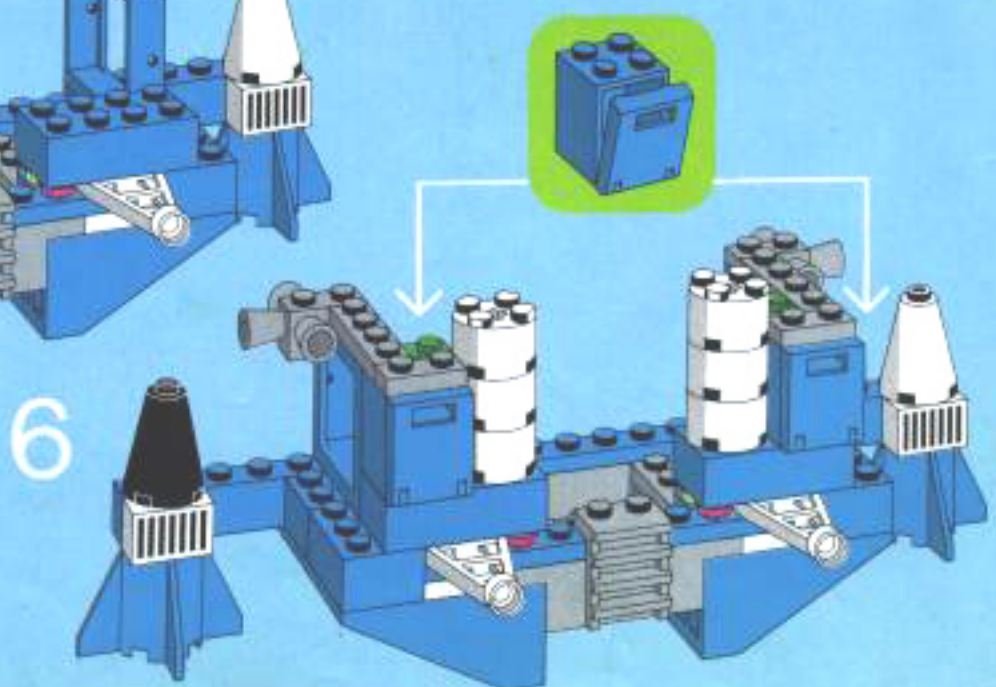
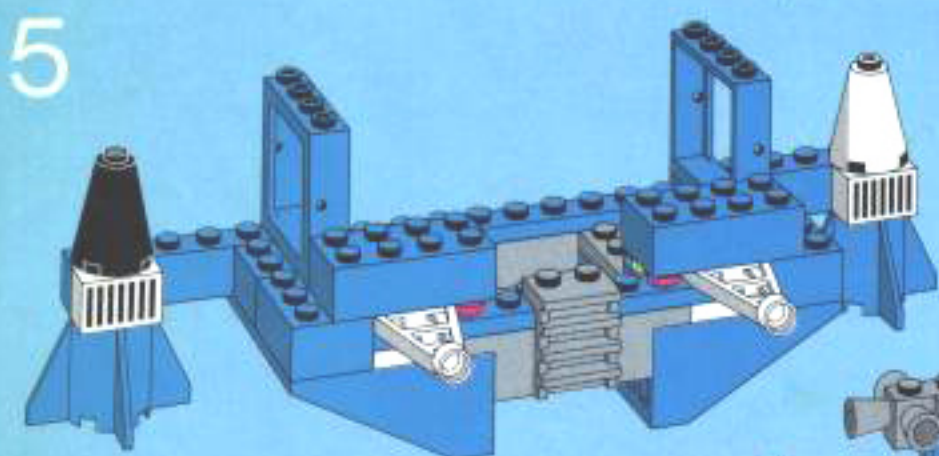
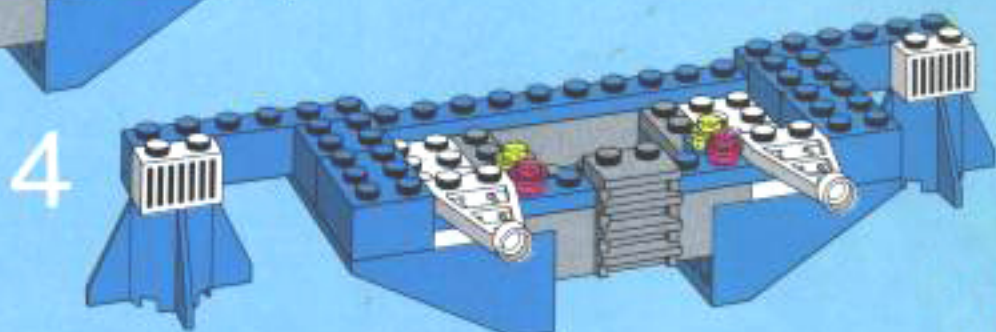
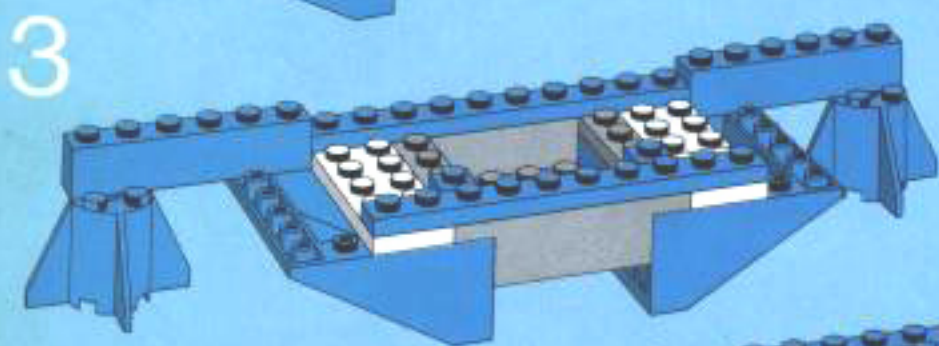
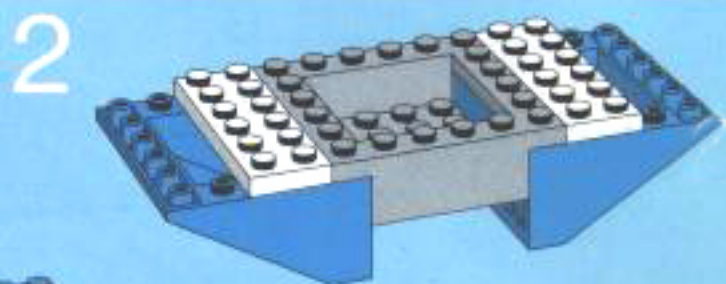
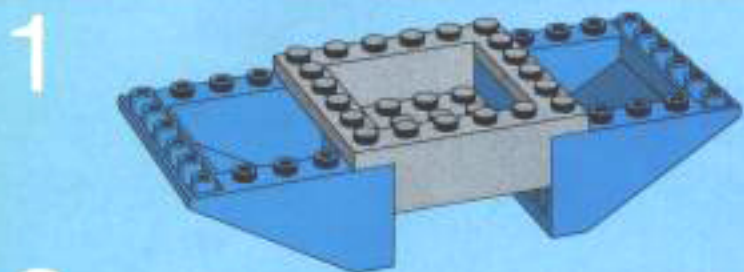



7

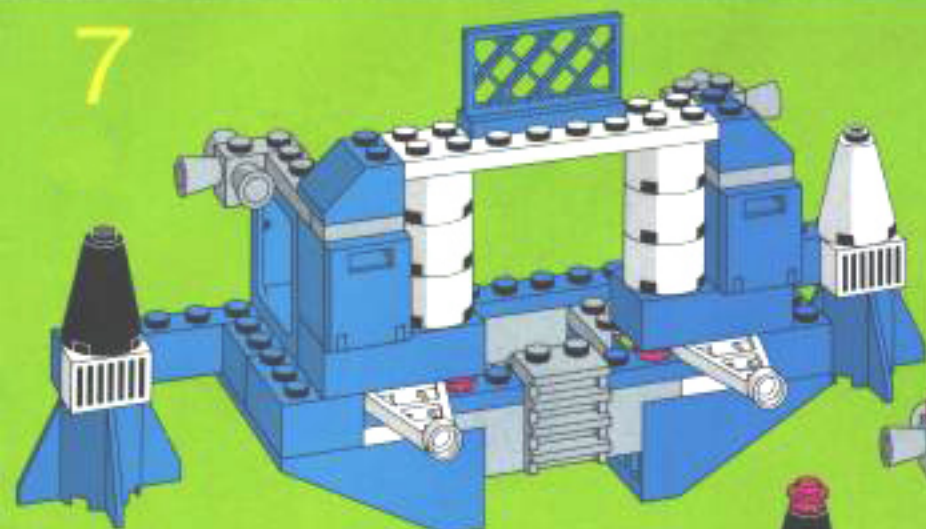

8

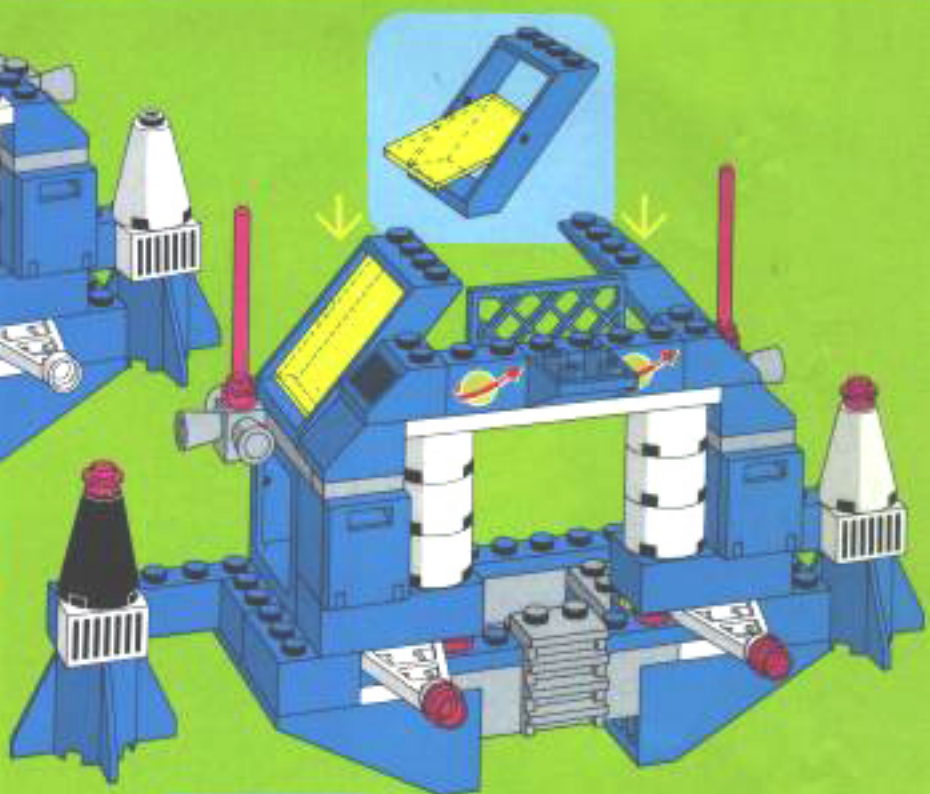

9

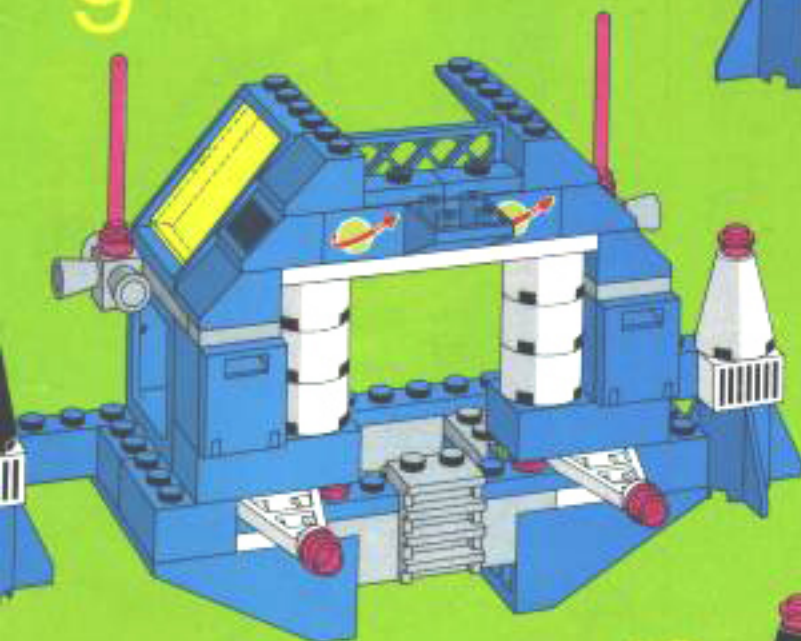

10

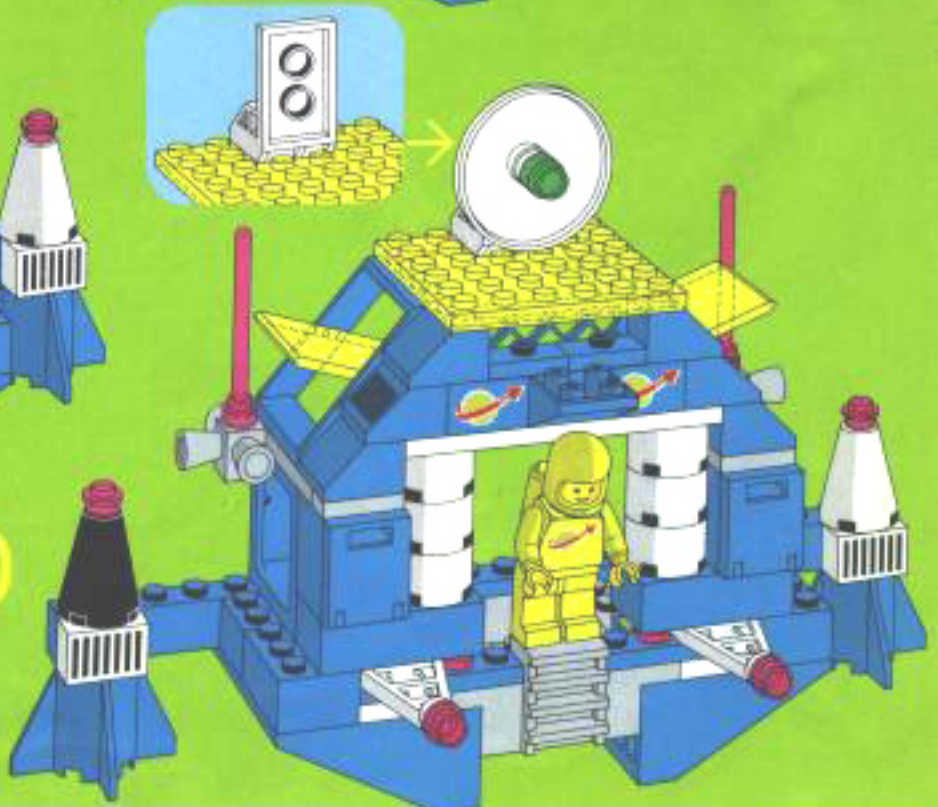

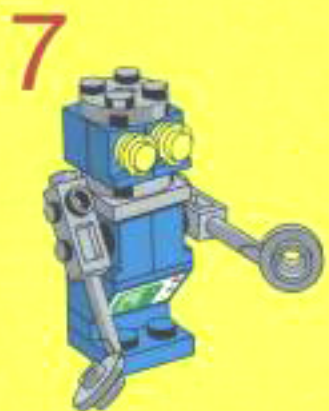
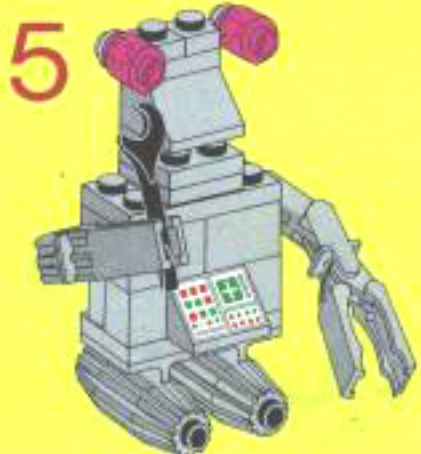
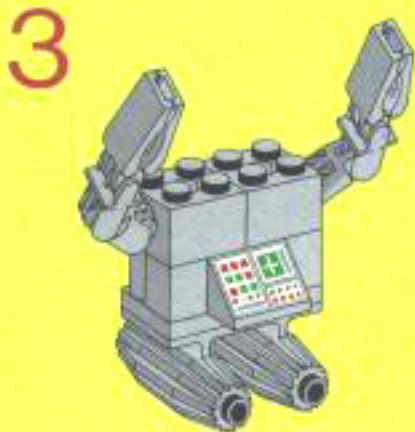
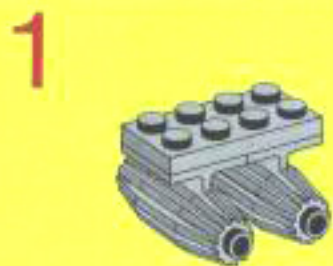

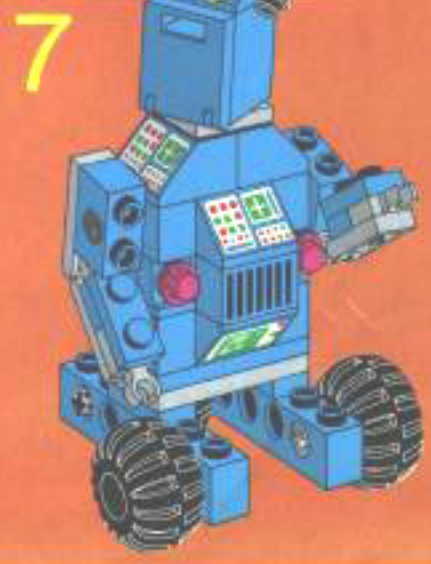
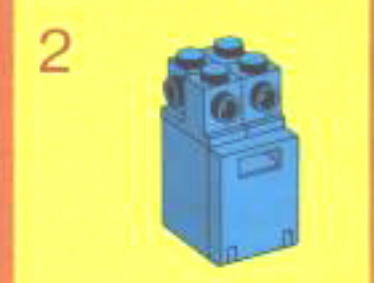
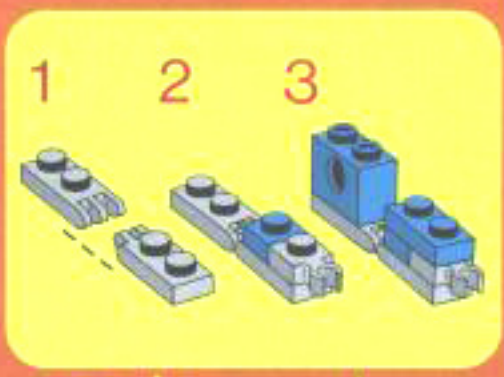
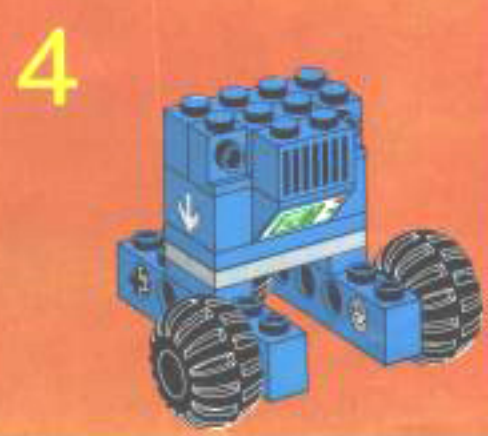
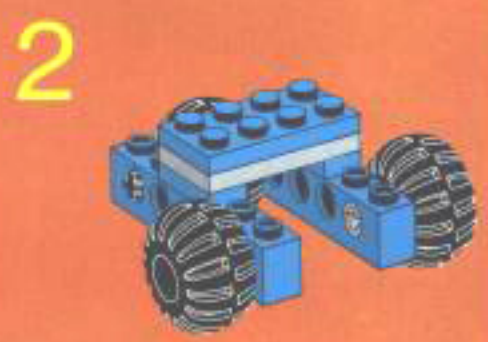
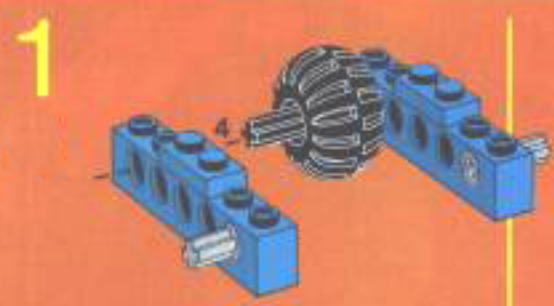







1

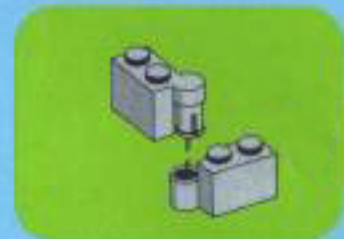
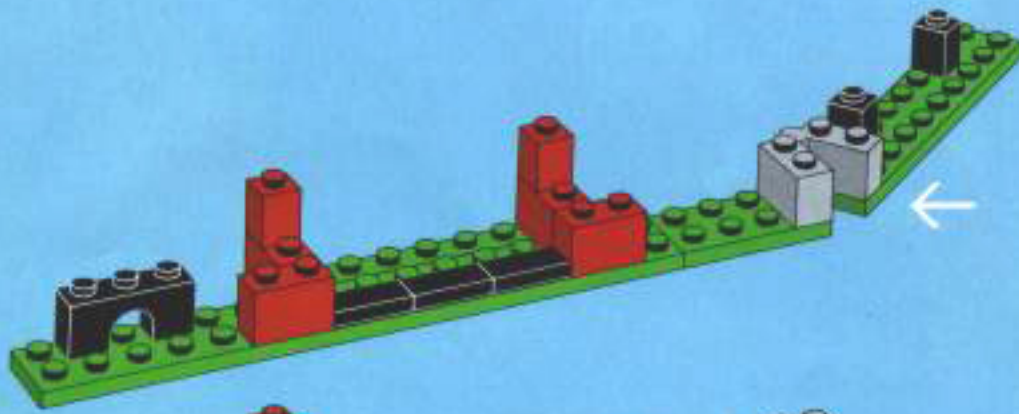

2

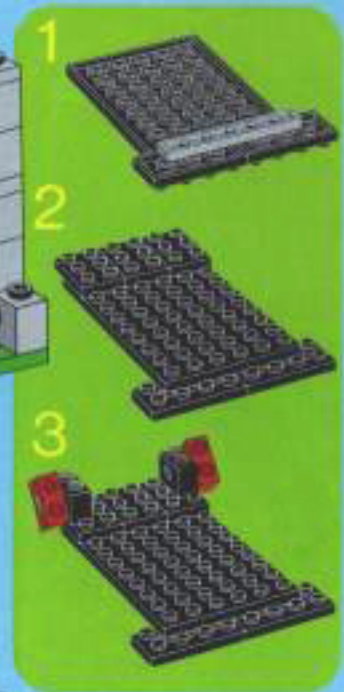
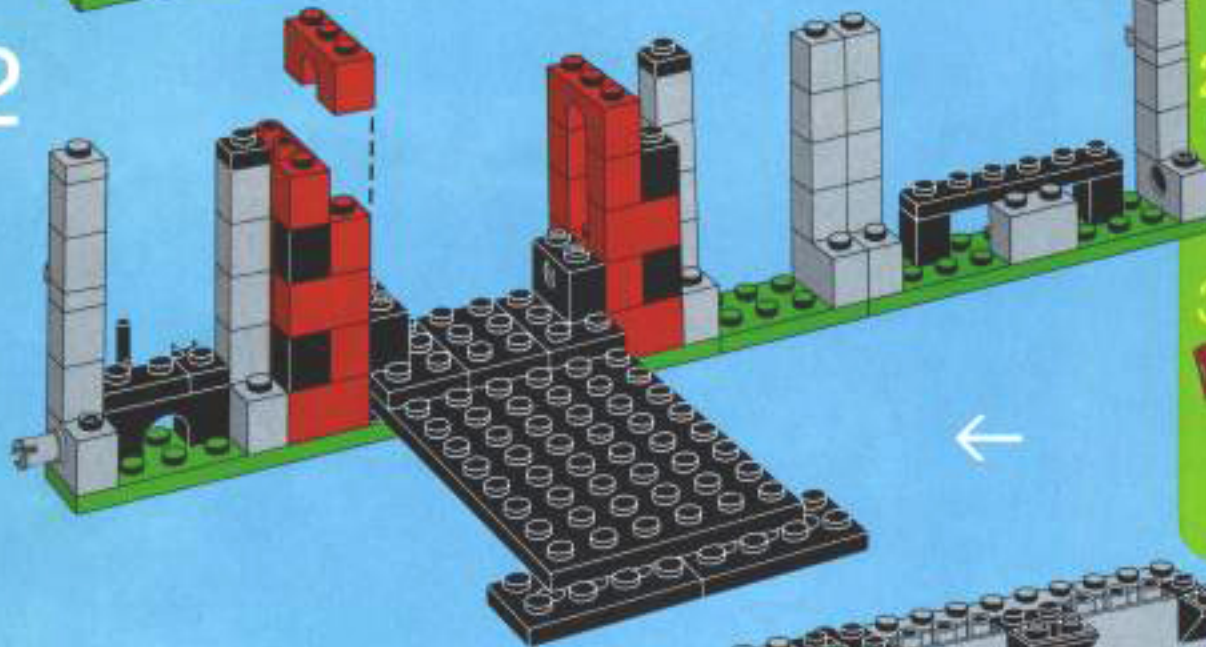

3

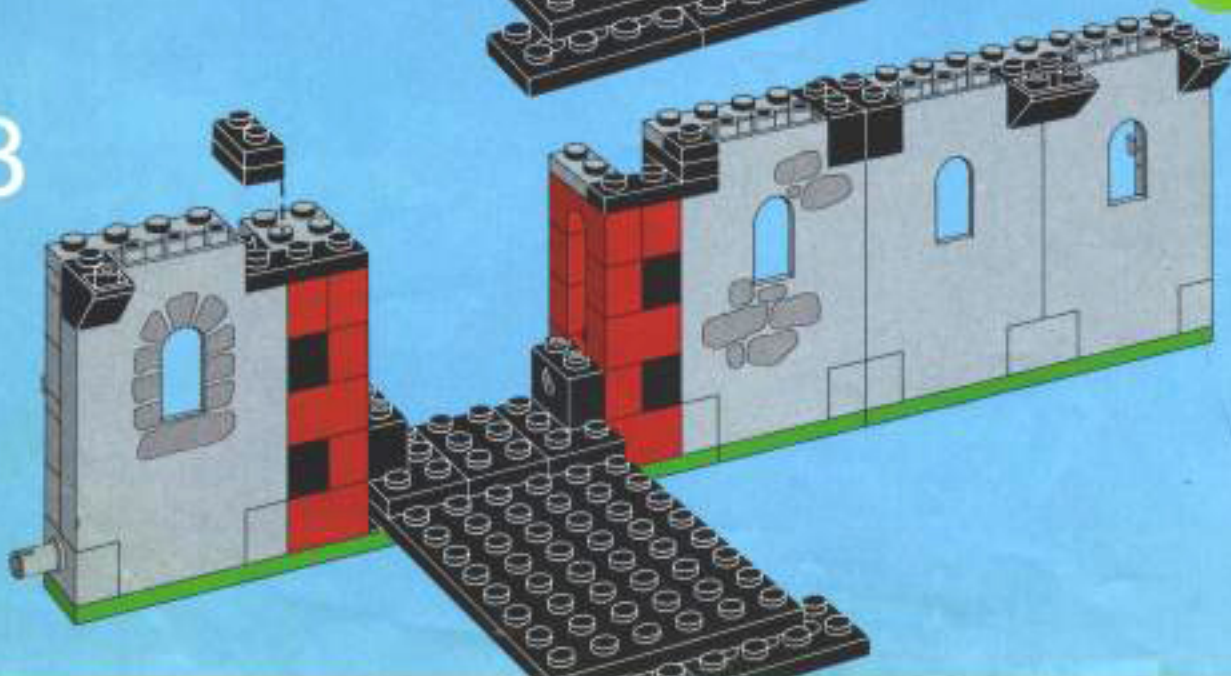



4

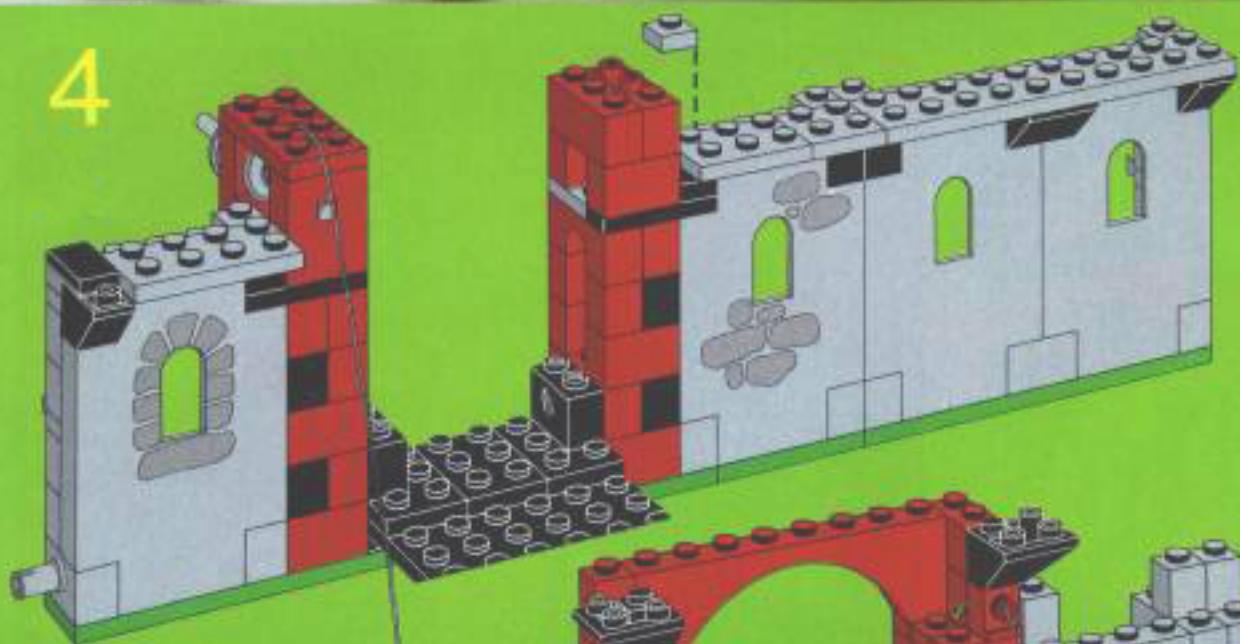

5

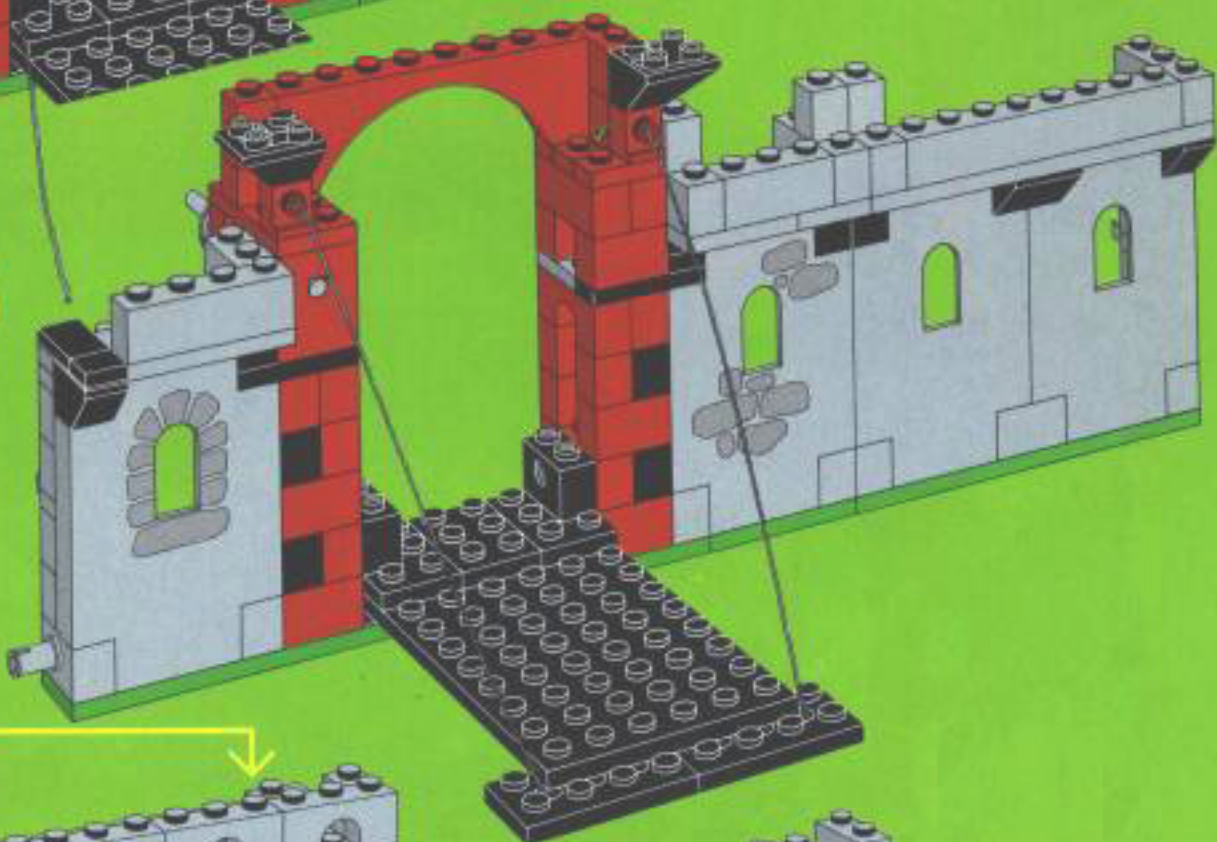

6





7

